



CHIPBLASTER V-SERIES HIGH PRESSURE COOLANT

CHIPBLASTER V-SERIES Modular Premium Models

Chipblaster V-Series high pressure coolant systems are variable rate high pressure units. These units are premium and modular units with options

	V-40	V-60	V2-80	V-120
Volumes	40 Liters Per Minute	60 Liters Per Minute	80 Liters Per Minute	120 Liters Per Minute
Pressures	1000 PSI			
Standard Coolant Tank Capacity	100 Gallons	126 Gallons	100 Gallons	126 Gallons



- V-40 and V-60 standard units include one module, product images shown include Chipblaster Chiller Series (second module)
- V2-80 and V-120 standard units include two modules, product images shown include Chipblaster Chiller Series (third module)



PERIPHERAL VISION

For CNC machine tool peripherals, it's **LNS**, then all the rest



CHIPBLASTER V-SERIES HIGH PRESSURE COOLANT

V-40



The Chipblaster V-40 goes well beyond conventional coolant systems to automatically provide optimal pressure and flow for all applications. This assures more accurate cutting, faster throughput and longer tool life. All in an affordable, custom-designed unit requiring minimal floorspace.

Most high-pressure coolant systems concentrate only on chip management and pump at a fixed rate, regardless of need. This wastes energy, especially when using smaller tools, as a majority of the coolant is simply dumped back into the tank. Chipblaster V-40 automatically delivers just the right amount of coolant to maintain optimal pressure and flow for each specific application, thus coolant is never bypassed. The result is energy savings and extended tool life. The Chipblaster 380 liter (100 gallon) standard tank with baffles radiates excess heat to maintain acceptable coolant temperature and reduce foaming.

Model	Flow	Pressure	Outlets	Tank	Hydracell
V-40	10 GPM	1000 PSI	1	100 Gallons	Optional
Options		Dimensions			
Oil Skimmer Chiller Mist Collector Cyclone Filtration Heater Wash Wand		62" x 24" X 75"			

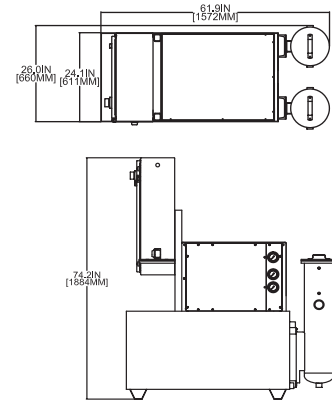

V2-80



The Chipblaster V2-80 can operate as two completely independent 40 liter (10 gpm) modules or combine to provide high pressure and very high volumes 80 liters at any time during the same program.

This is the "gold standard" for high pressure coolant systems. It automatically pumps just enough volume to maintain full pressure. Other systems pump a fixed rate that is always too much or too little causing foam, heat, and short filter life. Ideal for machine tools up to 40kw (50hp), dual turret lathes and 50 taper mills.

Model	Flow	Pressure	Outlets	Tank	Hydracell
V2-80	2 X 10 GPM	1000 PSI	2	100 Gallons	Optional
Options		Dimensions			
Oil Skimmer Chiller Mist Collector Cyclone Filtration Heater Wash Wand		62" x 30" X 75"			

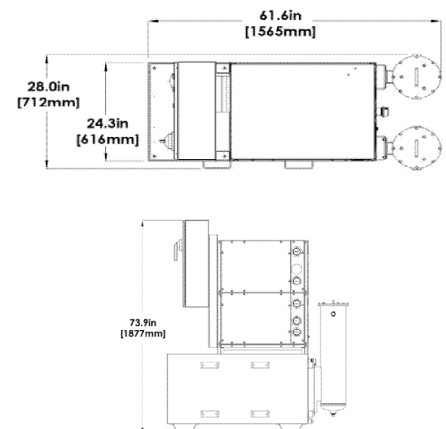

V-60



The Chipblaster V-60 is fed by a transfer pump that draws from the machine tool sump, through the filter vessel to the integral 480 liter (126 gal) tank. When the machine tool calls for coolant, the filter pump(s) draw the coolant from the Chipblaster tank and pumps it to the inlet of the positive displacement pump. The coolant then flows at high pressure through a series of distribution and safety valves and on to the machine tool. Ideal for machine tools up to 30kw (40hp), dual turret lathes and 50 taper mills.

This user-friendly interface makes operating and managing the Chipblaster V-60 system faster and easier. The HMI is pre-programmed for multiple languages, provides easy-to-read, plain text alarm screens, records critical alarm history data, allows the operator to view PLC I/Os in real time, and much more.

Model	Flow	Pressure	Outlets	Tank	Hydracell
V-60	16 GPM	1000 PSI	1	126 Gallons	N/A
Options		Dimensions			
Oil Skimmer Chiller Mist Collector Cyclone Filtration Heater Wash Wand		62" x 33" X 75"			

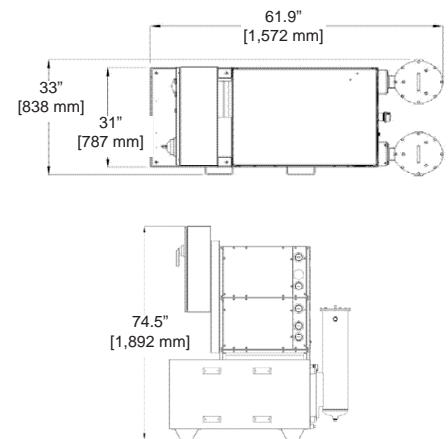

V2-120



The Chipblaster V2-120 can operate as two completely independent 60 liter (16 gpm) modules or combine to provide high pressure and very high volumes 120 liters at any time during the same program. Ideal for machine tools up to 60kw (80hp), dual turret lathes and 50 taper mills.

This user-friendly interface makes operating and managing the Chipblaster V2-120 system faster and easier. The HMI is pre-programmed for multiple languages, provides easy-to-read, plain text alarm screens, records critical alarm history data, allows the operator to view PLC I/Os in real time, and much more.

Model	Flow	Pressure	Outlets	Tank	Hydracell
V2-120	2 x 16 GPM	1000 PSI	2	126 Gallons	N/A
Options		Dimensions			
Oil Skimmer Chiller Mist Collector Cyclone Filtration Heater Wash Wand		62" x 33" X 75"			

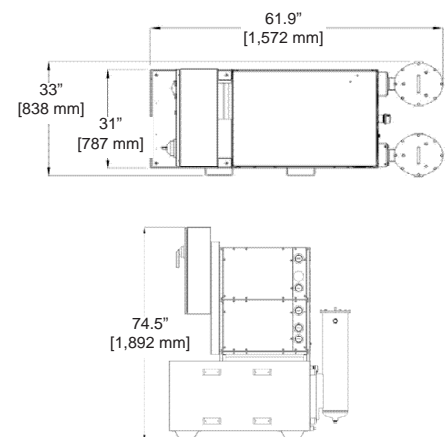



CHIPBLASTER ADDITIONAL ACCESSORIES

CHILLER SERIES



- 34,000 BTU
- Cooling capacity suits virtually all applications
- Optional heater for precise temperature control

Model	Dimensions
CC 34K	Included in base unit footprint
CC 34K SA	49" x 34" x 36"

FILTER SERIES



- Up to 100% filtering to 10 microns
- Up to 95% filtering to 5 microns
- Up to 50% filtering to 2 microns

Model	Dimensions
CF-79	Included in base unit footprint
CF-79 SA	27" x 25" x 38"

SLUDGE TANK

- Recommended to complement Chipblaster CF-79 cyclone filter. The Chipblaster sludge tank holds particulates outside of the machine-tool sump and is easy to access for cleaning.

Model	Dimensions
CB ST 200	37" x 18" x 26"

MIST COLLECTORS

Model	EMULSION			EMULSION OR OIL				
	Chipblaster MB 300	Chipblaster MB 700	Chipblaster 1200	Fox WS 2 170	Fox WS 2 330	Fox WS 2 700	Fox WS 2 1020	Fox WS 2 1250
Airflow (cfm)	300	700	1200	168	330	665	1012	1248
Motor (hp)	0.5	1	3	0.4	0.6	1.2	2.4	3.5
Amps at 230V	2.1	3.2	7.5	1.5	2	2.9	5.7	8.3
Weight (lb)	65	80	140	62	77	121	165	187
Sound Level (dB(A))	71	73	74	63	65	71	73	75
Suction Inlet Dia (in)	6	6	6	4	5	6	8	8

PERIPHERAL VISION

Peripherals, by definition, are an outer boundary. But at LNS, that boundary is where we put our focus. Because here's the secret—with LNS peripherals on your side, you can turn your attention to what you do best—making chips and making money.

That's why we do what we do. Five product categories and industry-best expertise means no company on earth can match the passion and vision we have for machine tool peripherals.



LNS ChipBLASTER
13605 S Mosiertown Rd
Meadville, PA 16335

814-724-6278
highpressure-sales@chipblaster.com
www.LNS-northamerica.com