

WasteWizard

Features and Benefits

The Osmonics® WasteWizard® system is a revolutionary new filtration technology for recycling of aqueous cleaner baths, mass finishing compounds, mopwater and certain other water-based industrial fluids. Designed as a low maintenance, point-of-use device for the factory floor, the WasteWizard system employs a patented process to filter out and collect the soils that reduce the useful life of these valuable fluids.

- z Re-purifies for reuse up to 85% of spent cleaners and coolants.
- z Drastically lowers disposal cost. Reduces oily waste generated by up to 99%.
- z Minimal operator attention.
- z Simple to use self-contained design.
- z Smart Diagnostics self control the unit under varying conditions.
- z No pre-filtration; made to handle high solids.
- z Automatic cleaning cycles via programmed permeate shut off.
- z Low cost, easy installation. Simple plug in and run design.
- z Small footprint, fits in 55 gal (200 L) drum.
- z Made for point-of-use simplicity.
- z Reliability: Over 1000 WasteWizard units on line today.
- z Patented Osmonics UltraFlic® membranes assure highest output.

Applications

The WasteWizard system's ability to recycle cleaners and finishing compounds continuously is unparalleled and can save many thousands of dollars in chemical usage, labor, waste processing and hauling. In addition, WasteWizard system recycled fluids will save on product rework costs by improving cleaning/finishing quality and consistency that typically go off-spec as the oil and dirt contaminants build up in the process sump.

- z Aqueous Cleaner Recycling
- z Mop Water Recycling
- z Vibratory Compound Recycling
- z Synthetic Coolant Recycling

No Filtration vs. Continuous Filtration

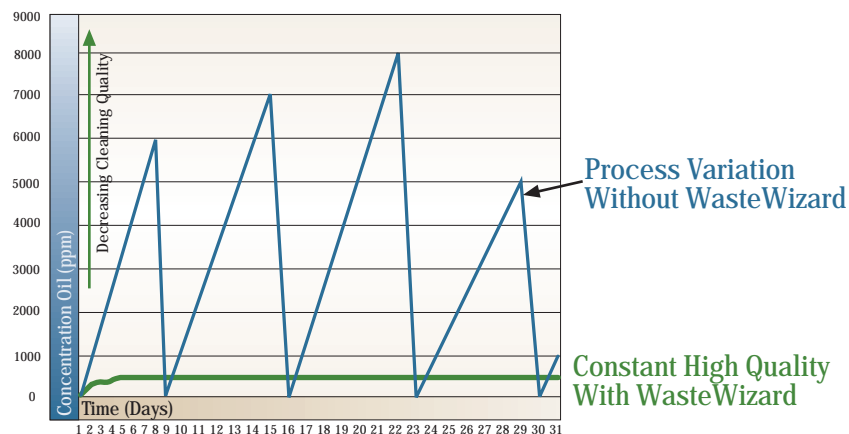

The WasteWizard system is a compact, fully-integrated system for point-of-use recycling. The system comes complete with its own fluid transfer system that automatically exchanges the dirty cleaner from the washer with recycled cleaner. The WasteWizard system sits on a standard 55 gallon (200 L) drum or optional 100 gallon (380 L) tank for convenient waste disposal once the oil and solids have been concentrated to a high level.

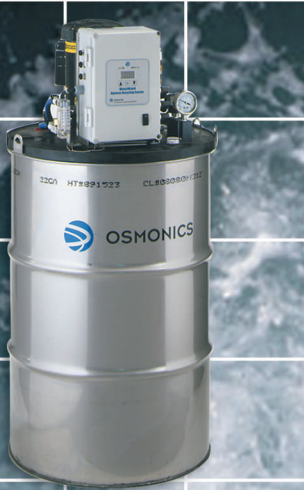

The Waste Wizard System

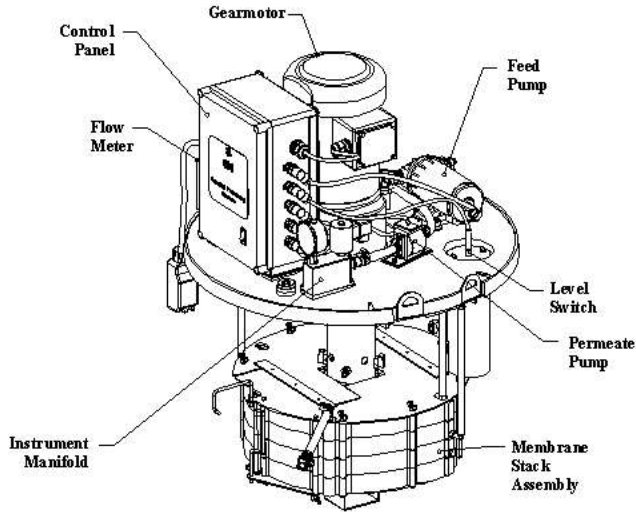

Continuous Filtration of Cleaner Bath

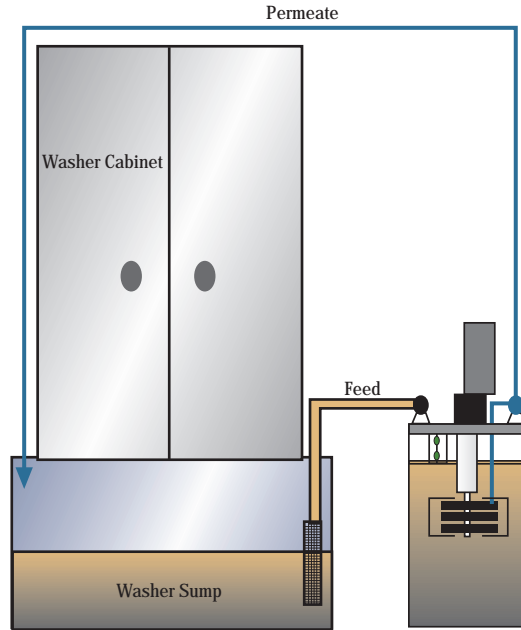

Approximate Dry Weight

- z 1 stack - 196 lbs (89 kgs)
- z 2 stack - 200 lbs (91 kgs)
- z 3 stack - 204 lbs (93 kgs)
- z 5 stack - 241 lbs. (110 kgs)

Boxed dimension for all machines:
25" x 25½" x 45½" (63.5 x 65 x 115.5 cm)

General Specifications

Model	GPD Permeate at 77°F	m3 per day at 25°C
WW-1	100	0.38
WW-2	200	0.76
WW-3	300	1.14
WW-4	400	1.51
WW-5	500	1.89

Maximum Temperature is 170°F (76°C)
pH Range is 2-11

Electrical Requirements

	WW-120	WW-460	WW-230	WW-380	WW-400
Power	120 Volts (13.5 AMPS) 1-Phase 60 Hz	480 Volts (3.5 AMPS) 3-Phase 60 Hz	230 Volts (7.6 AMPS) 1-Phase 50 Hz	400 Volts (4.3 AMPS) 3-Phase 50 Hz	400 Volts (2.4 AMPS) 3-Phase 50 Hz
Amps	15A	20A	16A	16A	16A