



**GMV-4  
MACHINE QUOTATION**



**EXPAND**<sup>™</sup>  
MACHINERY  
GEN MILL GEN TURN GENESH

20869 Plummer St. Chatsworth, CA 91311  
Toll Free: 888-542-6374 (US only)  
Phone: 818-349-9166 | Fax: 818-349-7286  
www.expandmachinery.com

## **GMV-4 Heavy-Duty Knee-Mill** **12" X 54" Table Size**

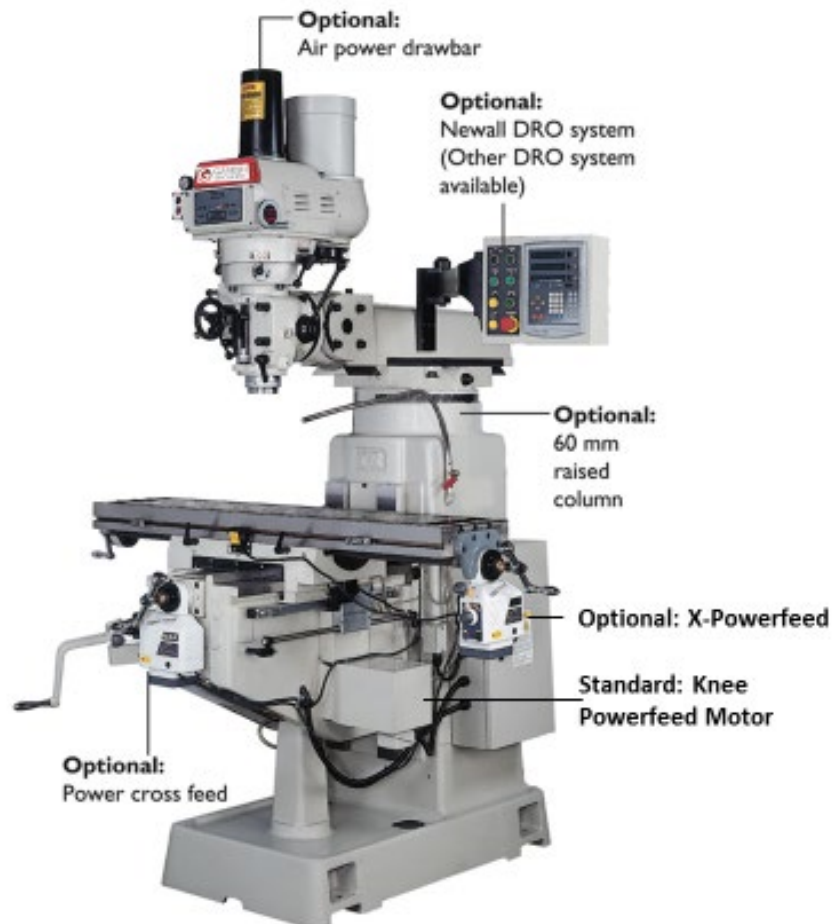

- **Class-7 Super Precision Fafnir Spindle Bearings**
- **5-Horsepower Variable Speed Head**
- **Square Box Ways on Knee & Column - Y & Z Axis**
- **1.5-Horsepower Knee Power Feed Motor**
- **Automatic Lubrication System for Slideways and Leadscrews**
- **Hard-Chrome Plated Quill**
- **40-Taper Spindle**

# **STANDARD GMV-4 MACHINE FEATURES:**

## **Machine Construction:**

- Meehanite Castings, fine grain and high density cast iron using the superior Meehanite process yields superior vibration dampening and improved surface finish and tool life
- Built-in leveling ledge to level machine low to ground
- Double table locks for increased machining rigidity

## **Table**

- Turcite-B Premium *Red Furon* Coated way surfaces (*Made in USA*)
- Hardened and Ground extra wide Box Way saddle for heavy-duty cutting performance
- Hardened and Ground Square Box Ways on Column and Knee
- Hardened and Ground Machine Table for enhanced wear resistance. Dovetail ways for longitudinal axis.

## **Spindle:**

- 5-HP Spindle Motor
- #40-taper spindle for superior metal removal capability
- ABEC Class-7 matched Super Precision spindle bearings
- Hardened, ground and polished precision Back Gear for quiet operation
- **Two high-output fans on spindle motor to provide extra cooling**
- Forward/ Reverse spindle switch housed in an oil-tight switch box
- Precision Spindle with 0.0002" maximum spindle runout – guaranteed!

## **Quill:**

- Power quill feed with 3-feeds and adjustable feed stop & automatic feed trip release
- Hardened and Ground Quill – **Hard chrome plated** for a long service life

## **Machine Features:**

- Hi -Torque knee powerfeed included to enhance operator efficiency
- Multiple knee and table locks for superior rigidity
- T-slots ground to 5/8" to fit standard workholding nuts
- Automatic Metered Lubrication for slideways and lead screws
- Spring Loaded way cover is included for added safety and protection of machine
- Built-in coolant pump is included
- Coolant & Chip Tray is included
- Water resistant halogen lamp is included
- Inspection Report on accuracy, Instruction Manual, Tools and Tool Box all included
- Large compliment of parts and accessories in stock to ensure continued operation

**THE BEST MILLS IN THE INDUSTRY!  
BACKED BY A FULL -SATISFACTION GUARANTEE**

# **STANDARD GMV-4 MACHINE SPECIFICATIONS:**

## **TABLE –**

<b>Table Size:</b>	12" X 54" (305mm X 1372mm)
<b>Table Capacity</b>	1200 lbs.
<b>T-slot width (3 Ground T-Slots)</b>	5/8" with ground reference edges (15.9mm wide)

## **MACHINE TRAVELS & CAPACITY –**

<b>Table Travel – X axis / (With Power Feed)</b>	36" / 33.8" (914/860mm) / 32" (812mm)
<b>Cross Travel – Y axis</b>	16" (400mm)
<b>Knee Travel – Z axis</b>	16" (406mm)
<b>Ram Travel</b>	17.7" (450mm)
<b>Spindle Nose-to-Table Travel</b>	2" – 18" (50 - 457mm)
<b>Quill Travel – Manual &amp; Power Feed</b>	5" (127mm)
<b>Quill feeds – With Trip Release</b>	0.0015", 0.003", 0.006" (0.038mm, 0.076mm, 0.152mm)
<b>Quill Diameter</b>	4.13" (105mm)
<b>Leadscrews with ground pitch (X &amp; Y)</b>	200" per rev. (5mm)

## **SLIDE WAYS -**

<b>Longitudinal Table – X Axis</b>	Hardened & Ground Meehanite Cast Iron
<b>Cross Slide to Knee – Y Axis</b>	Hardened & ground dovetail ways
<b>Knee to Column – Z Axis</b>	Hardened & ground square box ways

## **SPINDLE HEAD –**

<b>Head tilt (Left-to-Right)</b>	90 – 0 – 90 degrees
<b>Head tilt (Front-to-Back / Up-Down)</b>	45 – 0 – 45 degrees
<b>Head Swivel</b>	360-degrees
<b>Spindle Motor</b>	5-HP, 3-Phase 220 vac
<b>Spindle Taper</b>	NT #40 NMTB N.S. spindle taper
<b>Spindle Runout</b>	0.0002" maximum runout (0.005mm)
<b>Spindle Bearings</b>	ABEC-7 matched set of Class-7 bearings
<b>Variable Speed Drive - Dual Range</b>	80 - 520 rpm (low-range) / 520 - 4000 rpm (high-range)

**Note:** 5,000-RPM Electronic Variable-Speed Spindle available with the optional AC Inverter Spindle Head

## **DIMENSIONS & WEIGHT –**

<b>Power Requirements - 3-Phase</b>	220 vac @ 22-amps
<b>Coolant Capacity</b>	11-Gallons (41 liters)
<b>Machine weight</b>	3520 lbs. (1,600 kg)
<b>Machine Layout</b>	Width – 54" Depth – 66" – Height – 92"

**ONE FULL-YEAR WARRANTY PROVIDED –**

# **GMV-4 DELUXE Package:                    \$19,990.00**

**DELUXE ACCESSORY PACKAGE INCLUDED WITH EACH MACHINE - A \$3,500 VALUE**

1.5 HP Motorized Knee Power Feed	\$1,295	Value – Standard Included Feature
Spring Loaded Way Covers	\$ 495	Value – Standard Included Feature
2-Cooling Fans in Spindle Head	\$ 395	Value – Standard Included Feature
Halogen Work Light	\$ 395	Value – Standard Included Feature
Automatic Lubrication System	\$ 295	Value – Standard Included Feature
Coolant Pump & Nozzle	\$ 495	Value – Standard Included Feature
Coolant & Chip Tray	\$ 295	Value – Standard Included Feature

## **SPECIAL PACKAGE SAVINGS:**

**PACKAGE #1**      NEWALL/ FAGOR 3-axis Digital Readout  
Hi-Torque X-axis (table) powerfeed (Max Torque 650 in/lb).

**PACKAGE #2**      NEWALL / FAGOR 3-axis Digital Readout  
Hi-Torque X-axis (table) powerfeed (Max Torque 650 in/lb).  
Y-axis (cross) powerfeed, Z-axis (knee) powerfeed,  
Air-Power Drawbar w/ safety shut-off

- **MACHINE ONLY:**     **\$19,990.00**
- **With PACKAGE #1:**     **\$22,990.00**
- **With PACKAGE #2:**     **\$23,990.00**

## **GMV-4 MANUAL MILL OPTIONS**

- Factory machine installation:  
    “Peace-of-Mind Factory Installation” – includes expenses     \$1,995.00
- Newall/ Fagor 2-Axis Digital Readout installed     \$1,795.00
- Newall/ Fagor 3-Axis Digital Readout (3<sup>rd</sup> axis is on the quill) installed     \$2,350.00
- 4” Riser installed on your machine     \$750.00
- 8” Riser installed on your machine     \$995.00
- Wiring to 440 volts Net Price     \$395.00
- Hi-Torque Longitudinal Powerfeed installed     \$695.00
- Hi-Torque Cross Powerfeed installed     \$795.00
- Powerpac 40 Taper Air Power Drawbar installed     \$1,195.00

**A large compliment of spare parts is in stock at our facility in Chatsworth to ensure your continued operation.**

**Machine operation and service manuals are provided with each machine in electronic format on a USB memory stick. Printed manuals are also available for your use for a \$150 printing fee.**

**GMV-4 machines are manufactured in  
Our Certified ISO 9001 Factory in TAIWAN.**

## Floor Plan Layout

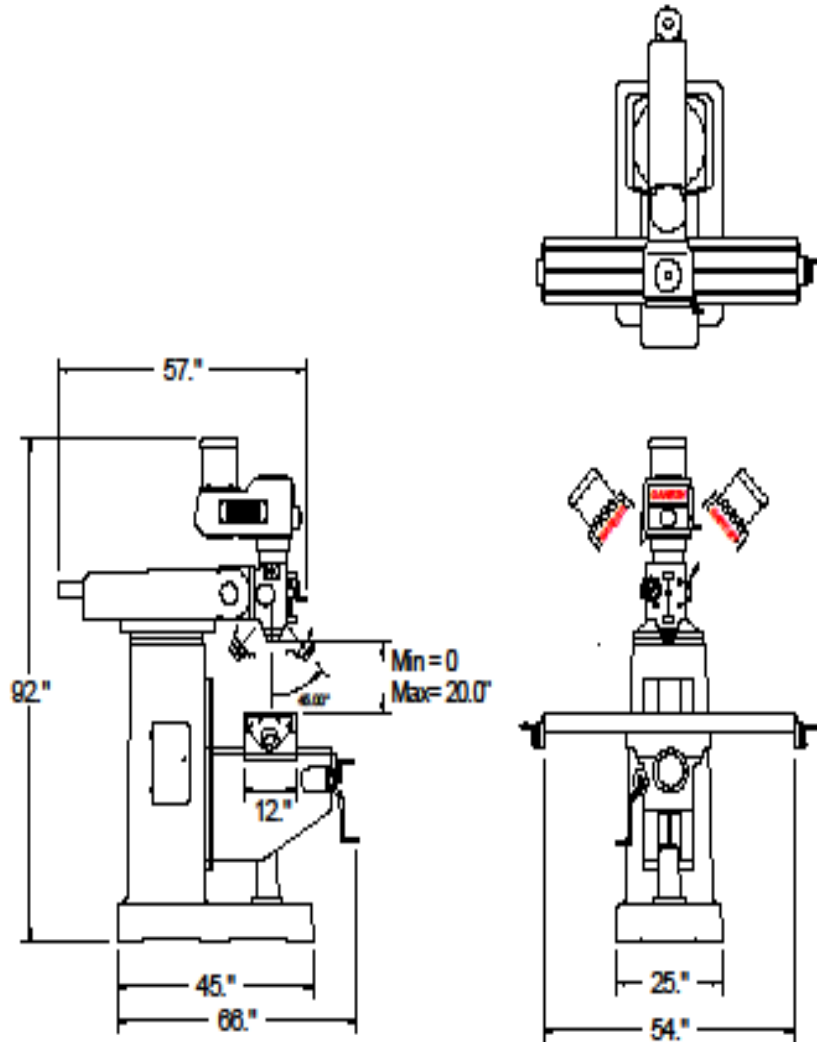

## **Terms of Sale**

**Warranty** – 1 full year parts warranty on the machine. Labor warranty will be provided by your local servicing distributor.

**Parts**– Spare parts are available at our facility in Chatsworth to support your continued machine operation.

**F.O.B. Point** – Machines ship F.O.B. from Chatsworth, CA 91311.

**Payment Terms** – 30% down payment with your Purchase Order secures the machine. 60% is due prior to machine shipment, and the 10% balance is due net-30 days after installation or the machine can be financed with our approved lender. Leases with \$1.00 buyout are available upon approved credit.

**Purchase is governed by the Expand Machinery terms and conditions of sale.**

**UL & TÜV ELECTRICAL APPROVAL IS AN AVAILABLE OPTION**

**Prices and specifications subject to change without prior notice.**



**HEADQUARTERS**  
CHATSWORTH, CA



**SHOWROOM**  
4,000 SQ. FT



**PARTS ROOM**  
FULLY STOCKED



**RECEPTION CENTER**



**SIMULATION ROOM**

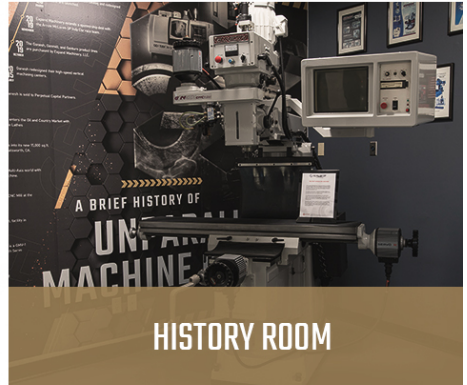

**HISTORY ROOM**



**SPONSORSHIPS**  
ARROW MCLAREN SP RACE TEAM



**TRAINING CENTER**  
IN-HOUSE TRAINING OPTIONS



## **EXPAND MACHINERY TERMS & CONDITIONS OF SALE**

### **General Offer & Applicable Law**

Products and services furnished by Expand Machinery (referred to herein as "Expand", "we", "us" and "our") are sold to you ("Customer") only on the terms and conditions stated herein. Notwithstanding any terms or conditions on Customer's orders, our performance of any contract is expressly made conditional on Customer's agreement to these terms and conditions of sale. We hereby reject any conflicting, different or additional terms and conditions proposed by Customer, unless otherwise specifically consented to in a writing signed by a duly authorized officer of Expand. To the extent that Customer attempts to place an order with us with open-ended terms (such as, but not limited to, without an end date that has been specifically agreed to in writing by an authorized representative of Expand or without a firm quantity commitment that has been specifically agreed to in writing by an authorized representative of Expand), such open-ended terms are specifically rejected by us and shall not be deemed to be part of any agreement or arrangement between us and Customer. Acceptance of any good or part thereof delivered by us or other assent by Customer to these Terms and Conditions of Sale (the "Terms") shall constitute an agreement to all of the Terms, including, without limitation, our limitations of warranty and liability. All contracts for the sale of products shall be construed under and governed by the laws of the State of California. All orders shall be subject to our acceptance.

### **Prices & Specifications**

All published prices and specifications are subject to change without notice. Unless otherwise specified in writing, all quotations are firm and expire thirty days after the date thereof. Unless otherwise stated, all prices, published or quoted, shall be exclusive of insurance and any and all taxes and transportation costs. All deposits are non-refundable.

### **Transportation & Acceptance**

We reserve the right to select the means of transportation and routing if we determine that Customer's instructions are unsuitable. Customer shall be responsible for all risk of loss and/or damage commencing upon delivery of the products to the transportation company at the F.O.B. point. Title to any products shall pass to Customer when products are delivered to the transportation company at the F.O.B. point. All products must be inspected by Customer immediately upon receipt and any claims should be filed with the transportation company when there is evidence of shipping damage, even if the damage is concealed. The furnishing of a product to Customer shall constitute acceptance of that product by Customer unless written notice of defect or nonconformity is received by us within ten-days of receipt of the product at Customers designated receiving address. We may repair or, at our option, replace defective or nonconforming parts after receipt of such notice of defect or nonconformity.

### **Performance**

Delivery dates and production figures are approximate and are based on the prompt receipt by us of all information and materials we deem necessary. Failure to deliver within the time estimated shall not be a breach of contract on our part, and in no event shall we be responsible for, or Customer be entitled to, any damages of any kind whatsoever arising out of or relating to any such delay in delivery. Without limiting the foregoing, acceptance of any good or part thereof by Customer shall constitute a waiver of any and all claims for delay. We shall be excused for delay in delivery and/or may suspend performance of any contract for the sale of products and services without liability to Customer in the event and to the extent of a "force majeure" which shall include, without limitation, strike, lockout, riot, act of civil or military authority, war, riot fire, flood, storm, explosion, act of God, act of Customer, pandemic, quarantine restriction, government order, delay in transportation, accident, or subcontractor or supplier delays or other events beyond our control. We reserve the right to substitute suitable products, when we determine in our sole discretion that such substitution is necessary due to a force majeure. No order may be terminated by Customer without our prior written consent. Machines are not designed to conform to UL or OSHA Standards. It is Customer's sole responsibility to verify the electrical standards applicable to any machines purchased subject to these terms and conditions in their locality.

### **Warranty & Liability for Machine Sales**

Our machines, including accessories and spare parts purchased and/or included with the machine sale, are guaranteed to be free from defects in workmanship for twelve months after the date of purchase, unless specified otherwise in writing. This warranty is effective only if the necessary information is provided: serial number of machine and nature of defect, and any part claimed defective is returned prepaid to us. No such return will be accepted unless we issue a returned material authorization (RMA) number. Upon its proper return to us, we shall repair or replace, at our option, the defective part. This warranty applies only if (a) our instructions as to installation, operation and maintenance have been completely followed; (b) the products have been used solely under normal operating conditions or procedures; (c) the products have been properly installed, operated and maintained and have not been affected by misuse, neglect or accident; (d) Customer has not attempted or performed (or caused to be attempted or performed) any type of repair or corrective work or modification without our prior written consent and (e) we shall have received written notice of any defect no later than thirty days after Customer first has knowledge of same. THIS WARRANTY IS EXPRESSLY IN LIEU OF, AND EXCLUDES ALL OTHER EXPRESS, IMPLIED OR STATUTORY WARRANTIES INCLUDING, BUT NOT LIMITED TO, WARRANTIES OF MERCHANTABILITY AND FITNESS FOR PARTICULAR PURPOSE, USE OR APPLICATION AND ALL OTHER OBLIGATIONS OR LIABILITIES ON OUR PART. The machine is not guaranteed to make specific parts. Customer is responsible for studying the machine's specifications to make its own determination that it can machine the desired parts. The remedy of repair or replacement, as provided herein, shall be the Customers exclusive remedy and will satisfy all our liabilities whether based upon contract, negligence, or otherwise. In no event shall we be liable for indirect, incidental, exemplary, punitive, special, or consequential damages of any nature whatsoever, including, without limitation, lost profits, loss of time or use of product, inconvenience, commercial loss, or injury or damage to persons or property, or failure of any good or part thereof to comply with any law.

### **Warranty & Liability for Accessory & Spare Part Sales**

Accessories and spare parts purchased after the original machine sale are guaranteed to be free from defects in workmanship for 90-days after the date of purchase, unless specified otherwise in writing. This warranty is effective only if the necessary information is provided: original date of purchase and nature of defect, and any part claimed defective is returned prepaid to us. No such return will be accepted unless we issue a returned material authorization (RMA) number. Upon its proper return to us, we shall repair or replace, at our option, the defective part. This warranty applies only if (a) our instructions as to installation, operation and maintenance have been completely followed; (b) the products have been used solely under normal operating conditions or procedures; (c) the products have been properly installed, operated and maintained and have not been affected by misuse, neglect or accident; (d) Customer has not attempted or performed (or caused to be attempted or performed) any type of repair or corrective work or modification without our prior written consent and (e) we shall have received written notice of any defect no later than thirty days after Customer first has knowledge of same. THIS WARRANTY IS EXPRESSLY IN LIEU OF, AND EXCLUDES ALL OTHER EXPRESS, IMPLIED OR STATUTORY WARRANTIES INCLUDING, BUT NOT LIMITED TO, WARRANTIES OF MERCHANTABILITY AND FITNESS FOR PARTICULAR PURPOSE, USE OR APPLICATION AND ALL OTHER OBLIGATIONS OR LIABILITIES ON OUR PART. The machine is not guaranteed to make specific parts. Customer is responsible for studying the machine's specifications to make its own determination that it can machine the desired parts. The remedy of repair or replacement, as provided herein, shall be the Customers exclusive remedy and will satisfy all our liabilities whether based upon contract, negligence, or otherwise. In no event shall we be liable for indirect, incidental, exemplary, punitive, special, or consequential damages of any nature whatsoever, including, without limitation, lost profits, loss of time or use of product, inconvenience, commercial loss, or injury or damage to persons or property, or failure of any good or part thereof to comply with any law.

### **Indemnity and Hold Harmless**

Customer agrees to indemnify, defend, and hold us harmless from any claims, liability, costs, expenses, obligations or losses incurred in connection with the sale, operation or use of any product, good or part which is the subject of this sale, including, but not limited to, unattended use of the equipment, bodily injury or death or any fire or other calamities resulting from Customer's use of any machine sold hereunder whether any such claims, liability, costs expenses or losses are suffered by Customer or any third party. Customer shall assume the sole responsibility and all risk for any and all loss, damage, or injury (including death) to any and all persons (including, without limitation, to employees and agents of Customer and us) and to all property in connection with the performance of its obligations hereunder or any act or omission of Customer, and shall indemnify, defend, and hold us harmless from and against any and all claims, liabilities, expenses (including, without limitation, attorneys' fees), fines, penalties, damages, and economic losses of whatsoever nature associated therewith, except for such claims, liabilities, etc. caused by our gross negligence or willful misconduct of Seller.

### **Compliance with Manuals, Instructions and Good Safety Practices; Compliance with Laws**

Customer shall be responsible for ensuring compliance by its personnel and others given access to any products in Customer's possession or control with all operating and maintenance manuals and instructions provided by us or any of our distributors and with other normal safety, operation and maintenance practices commonly observed in the industry. Compliance with local, state or federal laws, codes, directives or regulations relating to the products and their use is the sole responsibility of Customer, and we make no warranty or representation with respect thereto.

**Terms of Payment**

All payments for products released and shipped on approved credit accounts shall be due in full thirty days from the date of invoice. Past due balances shall be subject to a service charge of 1.5% per month or, if lower, the highest rate permitted under law. Partial shipments will be billed as made and payments therefore are subject to the above terms. All deposits are non-refundable. We may cancel or delay delivery of products or services in the event Customer fails to make prompt payment therefore or in the event of arrearage in Customers account. To secure the full and prompt payment and performance of any and all debts, liabilities, agreements, covenants, warranties, obligations, and amounts from time to time now or hereafter owing by Customer to us and/or to any of our affiliates (the "Obligations"), Customer, in consideration of our obligations hereunder, and for other good and valuable consideration, the receipt and sufficiency of which are hereby acknowledged, grants to us, for ourselves and as agent for each and all of our affiliates (as the case may be, the "Secured Party") a continuing first priority security interest in and lien against any good or part thereof tendered for delivery to Customer by us or any of our affiliates, together with any and all additions, accessions and replacements thereto and proceeds and products thereof, whether now owned or existing or hereafter acquired or coming into existence (collectively, the "Collateral"). Customer agrees that any good or part thereof tendered for delivery by us or any of our affiliates will be used primarily for business purposes. Customer irrevocably appoints Secured Party as Customer's attorney-in-fact with full authority to take any action and to prepare, execute and/or file any instrument that Secured Party deems necessary to carry out the terms herein and to perfect, and maintain the perfection of, Secured Party's lien against and first priority security interest in the Collateral. Customer agrees to pay any and all costs and expenses in connection with the actions taken by Secured Party in connection with the preceding sentence, or to reimburse Secured Party for the same. Without limiting the foregoing, we maintain all rights of a secured party by reference to applicable Uniform Commercial Code provisions in effect in each state in which the products are located.

**Arbitration**

All disputes under any contract concerning products sold to Customer pursuant to these terms and conditions that are not otherwise resolved between Customer and us shall be resolved through mandatory and binding arbitration to be conducted in Los Angeles, California and in accordance with the Judicial Mediation Arbitration Service ("JAMS") strictly in accordance with the terms of the contract, these terms and conditions and the substantive laws of the State of California, before a single arbitrator knowledgeable in the subject matter of the dispute selected in accordance with the procedures of the JAMS. The parties hereby consent to the service of process by registered mail, return receipt requested or by any other manner provided by the laws of the State of California and hereby waive any claims or defenses based on venue or forum non conveniens. Any related arbitration award will be final, conclusive and binding upon the parties and any judgment thereon may be entered and enforced in any court of competent jurisdiction. To the extent reasonably practicable, all disputes of a similar subject matter relating to more than one contract between any one Customer and us concerning products sold pursuant to these terms and conditions shall be consolidated into a single arbitration proceeding.

**Attorneys' Fees**

Should any legal action or arbitration be brought for the enforcement of these terms and conditions, or due to any alleged dispute, breach, default or misrepresentation in connection with any provisions herein, the non-prevailing party shall pay all reasonable attorneys' fees, expert witness fees and other costs and expenses, as well as arbitration costs and recoverable court costs, incurred by the prevailing party in any such action or proceeding and any action to enforce a judgment (including bankruptcy representation) and any appeal, in addition to such other relief, as may be granted to the prevailing party by the arbitrator or, if applicable, a court.

**Fire Waiver**

Customer shall be solely responsible for the appropriate use of the products, including, without limitation, the machining of certain metals that use oil as the cutting and cooling medium which can provoke the ignition of oil mists, fillings, chips or parts of a machine which could cause considerable damage to a machine and its surroundings. By accepting the products sold hereunder, Customer assumes this risk and is hereby required to use best efforts to avoid such incidents and to limit any potential risk or exposure to life and property arising therefrom. For the avoidance of doubt, we are not responsible for any fires on the machine.

**Assignment**

Customer's assignment of its order, or of any interest thereof or of any right of Customer against Expand or obligation of Customer to Expand, without our prior written consent, shall be void and shall entitle us to cancel such order and to obtain from Customer any applicable cancellation charges. We may assign our rights and/or obligations relating to Customer's order(s) to Expand upon notice to, but without the necessity of the consent of, Customer.

# CREDIT APPLICATION

Fax completed form to **818.349.9166**  
or email to [accounting@expandmachinery.com](mailto:accounting@expandmachinery.com)



## Company Information

COMPANY NAME			
ADDRESS			
CITY		STATE	ZIP CODE
COMPANY PHONE		COMPANY FAX	
COMPANY EMAIL		COMPANY WEBSITE	
DATE COMPANY ESTABLISHED	COMPANY TAX ID NUMBER	ANNUAL SALES	NO. OF EMPLOYEES

## Owner(s) Information

### Owner 1

FIRST NAME	LAST NAME	PERCENT OF OWNERSHIP
HOME ADDRESS		
CITY	STATE	ZIP CODE
PHONE	SOCIAL SECURITY NUMBER	

### Owner 2

FIRST NAME	LAST NAME	PERCENT OF OWNERSHIP
HOME ADDRESS		
CITY	STATE	ZIP CODE
PHONE	SOCIAL SECURITY NUMBER	

## Equipment Information

EQUIPMENT DESCRIPTION	
PURCHASE PRICE	VENDOR NAME

## Bank Reference

BANK NAME	BANK CONTACT	BANK ADDRESS
BANK PHONE	ACCOUNT NUMBER	

Submission of this application by each individual named above authorizes Expand Machinery, LLC, Inc. and its agents and affiliates, to conduct inquiries regarding the undersigned's business operations and individual and business credit histories as it may deem necessary. This may include, without limitation, requesting credit reports, contacting banks and secured lenders, lessors and trade creditors for references.

SIGNATURE

DATE

---