

0801
5
0610
15
0620
25
0630
35
0640
45
0650
55
0660
65
0670
F

承認 APPROVED	検閲 CHECKED	設計 DESIGNED	製図 DRAWN	第二図番 PRIMARY DWG. NO.	形式 MODEL	名称 NAME
		5942 KAMBE	5942 KAMBE	505EL0096B3	OGM-Series	SCHEMATIC DIAGRAM
		930526	950424	岡本工作機械製作所 OKAMOTO MACHINE TOOL WORKS. LTD.	分類コード C.CODE 3410	図番 DRAWING NO. PAGE 06

0701 AC100/100~110V±10% 50/60HZ 1φ

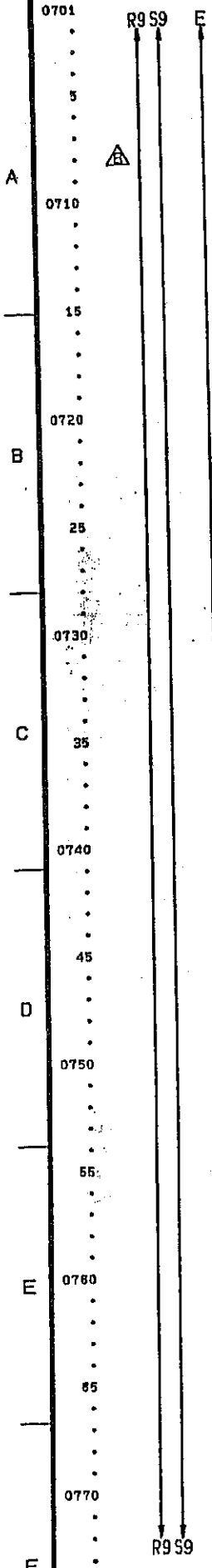

承認 APPROVED	検図 CHECKED	設計 DESIGNED	製図 DRAWN	第二図番 PRIMARY DWG. No.	形式 MODEL	名称 NAME
		5942 KAMBE	5942 KAMBE	505EL0097B3	OGM-Series	SCHEMATIC DIAGRAM
				岡本工作機械製作所 OKAMOTO MACHINE TOOL WORKS LTD	分類コード C. CODE	図番 DRAWING NO.
					3110	頁 P 0

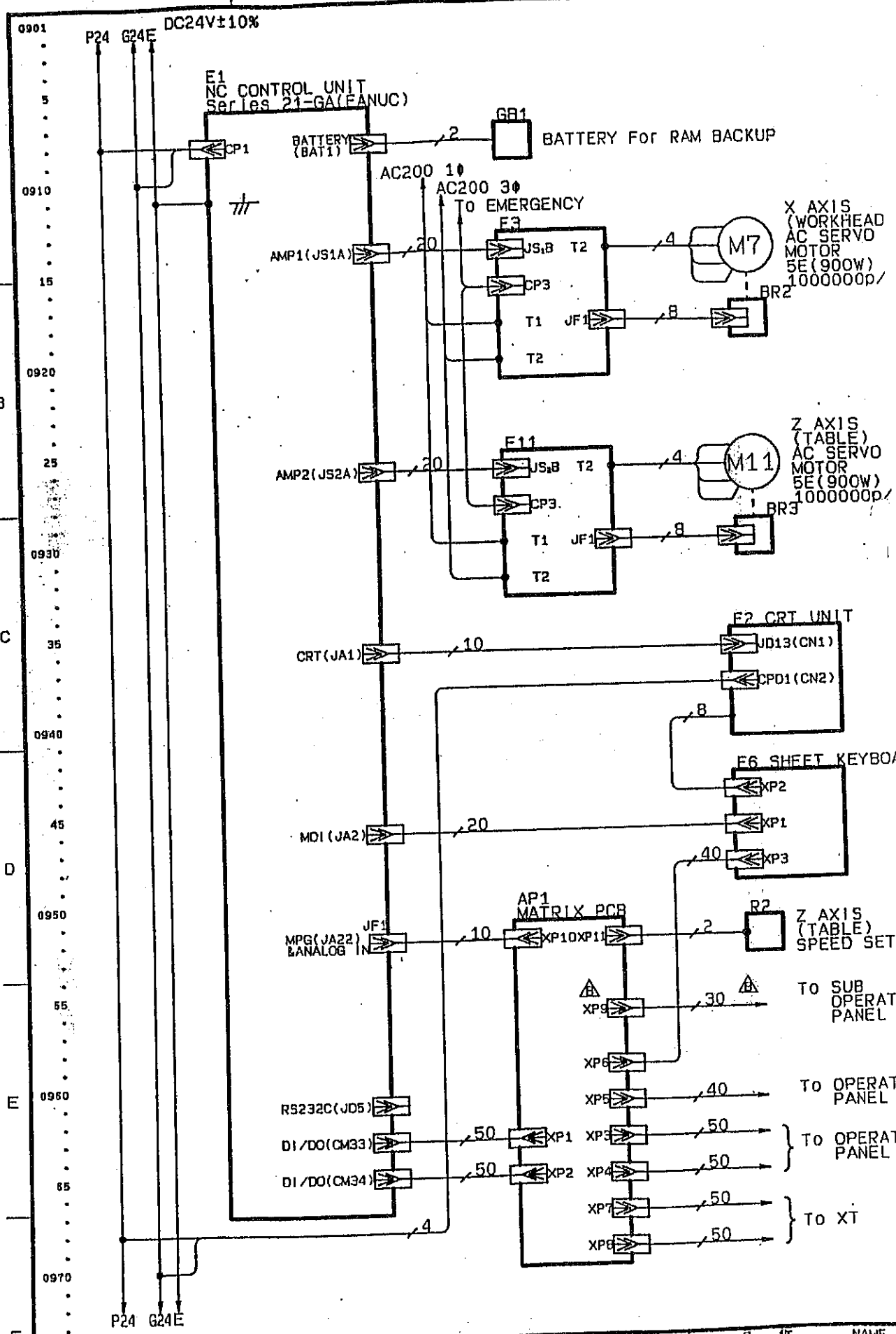

A
0910
15
B
0920
25
C
0930
35
0940
45
D
0950
55
E
0960
65
0970
F

承認 APPROVED	検図 CHECKED	設計 DESIGNED	製図 DRAWN	第一図時 PRIMARY Dwg. No.	形式 MODEL	名作 NAME
		5942 KAMBE	5942 KAMBE	505EL009983	OGM-Series	NC GENERAL INTERCONNECTION DIA
		930721	940224	岡本工作機械製作所 OKAMOTO MACHINE TOOL WORKS LTD	分冊下 C.CODE 3430	図番 DRAWING No.
						頁 0

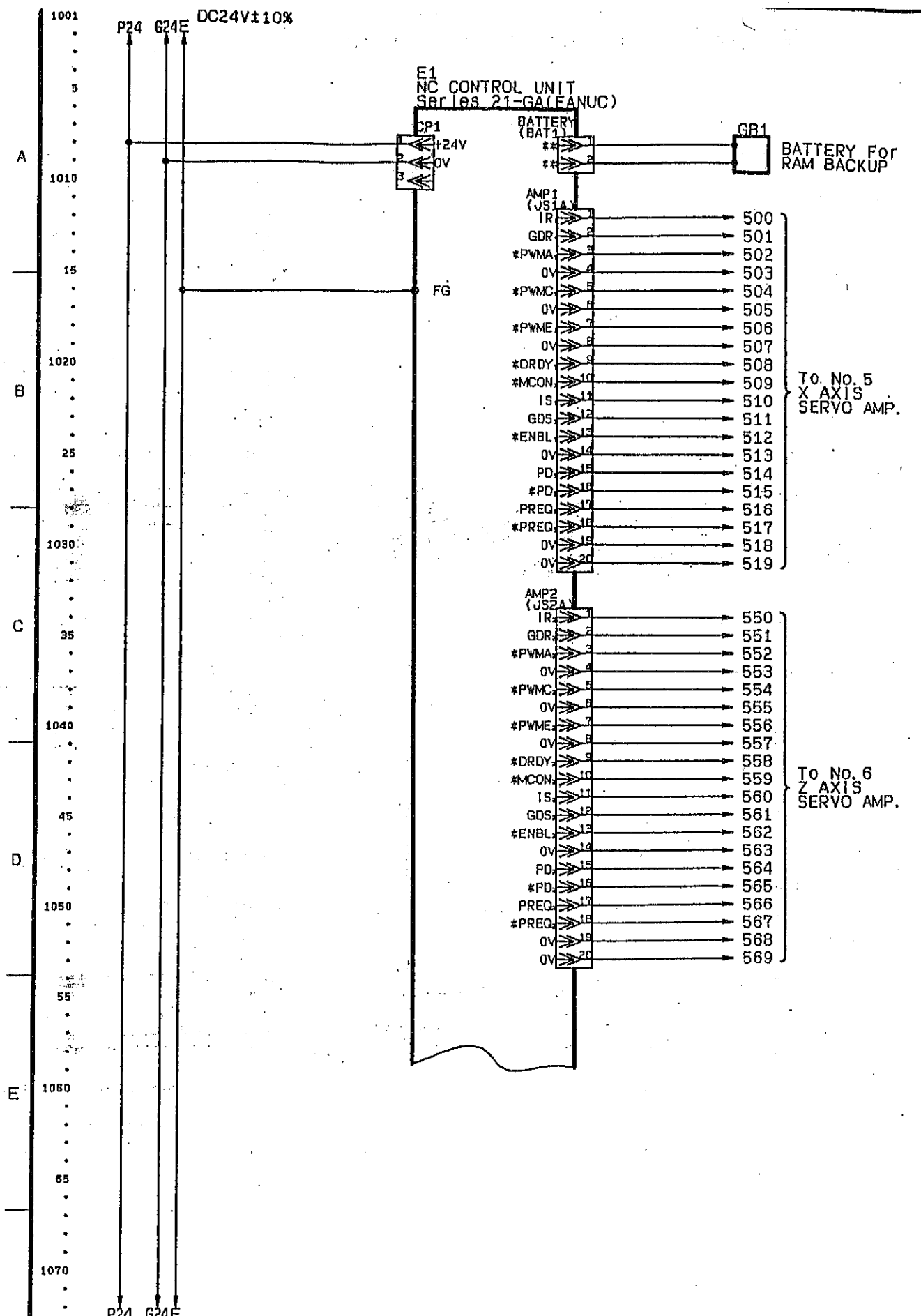

承認 APPROVED	検図 CHECKED	設計 DESIGNED	製図 DRAWN	第二図番 PRIMARY DNG. NO.	形式 MODEL	名称 NAME
		5942 KAMBE	6423 OZAWA	505EL0100A3	OGM-1224	SCHEMATIC DIAGRAM
		930526	930812	岡本工作機械製作所 OKAMOTO MACHINE TOOL WORKS, LTD.	図番 DRAWING NO. 3430	頁 PAGE 10

E1
NC CONTROL UNIT
Series 21-GA(FANUC)

1101
.
.
5
.
.
A
1110
.
.
15
.
.
B
1120
.
.
25
.
.
C
1130
.
.
35
.
.
D
1140
.
.
45
.
.
E
1150
.
.
55
.
.
1160
.
.
65
.
.
1170
.
.
F

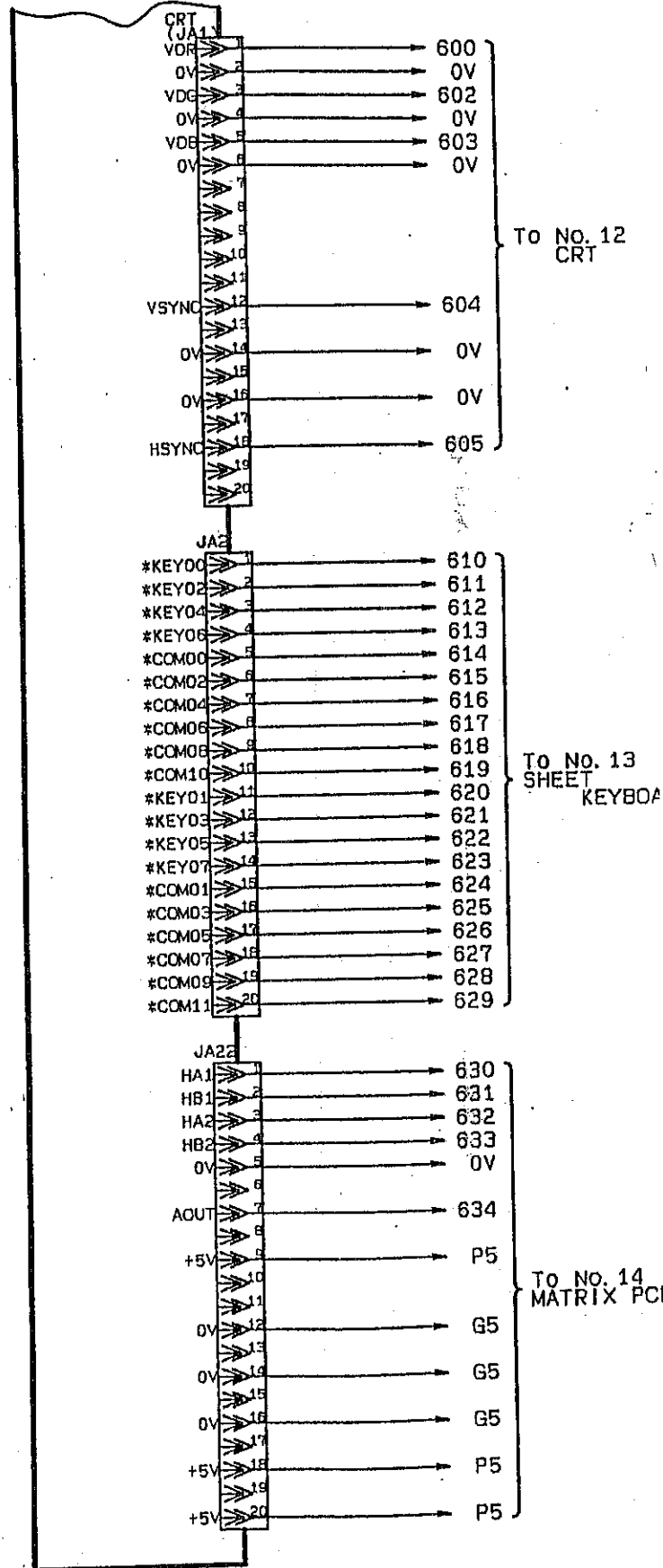

承認 APPROVED	検閲 CHECKED	設計 DESIGNED	製図 DRAWN	第一図番 PRIMARY ENG. NO.	形式 MODEL	名件 NAME
		5942 KAMBE	6423 OZAWA	505EL0101A3	OGM-1224	SCHEMATIC DIAGRAM
				岡本工作機械製作所	分類コード C.C00E	図番 DRAWING NO.
						頁 F

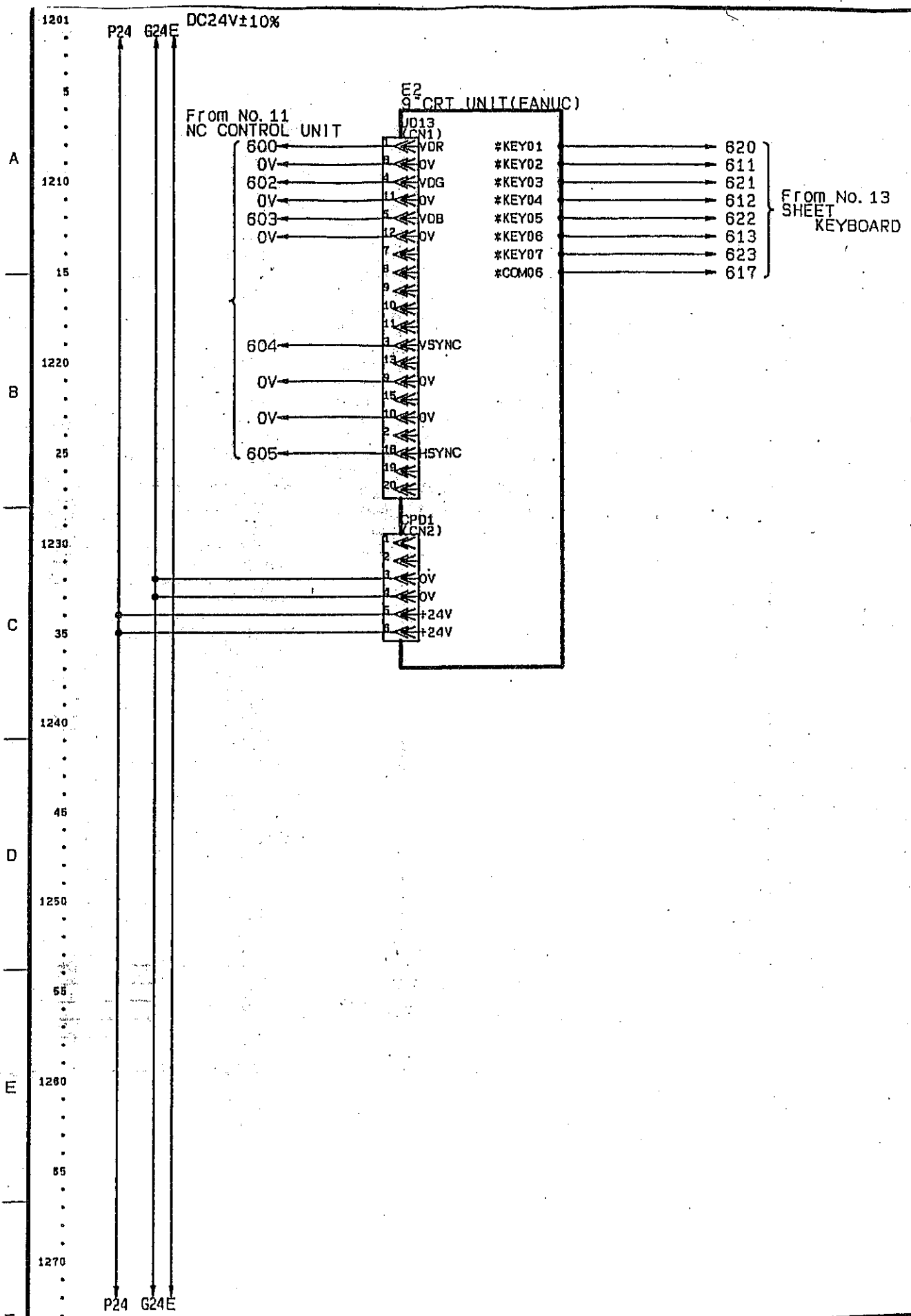

RD

承認 APPROVED	検 CHECKED	設計 DESIGNED	製 DRAWN	第二図番 PRIMARY DWG. NO.	形式 MODEL	名 NAME
		5942 KAMBE	6423 OZAWA	505EL0102A3	OGM-1224	SCHEMATIC DIAGRAM
		930526	930812	岡本工作機械製作所 OKAMOTO MACHINE TOOL WORKS, LTD.	分組一下 C CODE 3430	図番 DRAWING NO.
						頁 PAGE 12

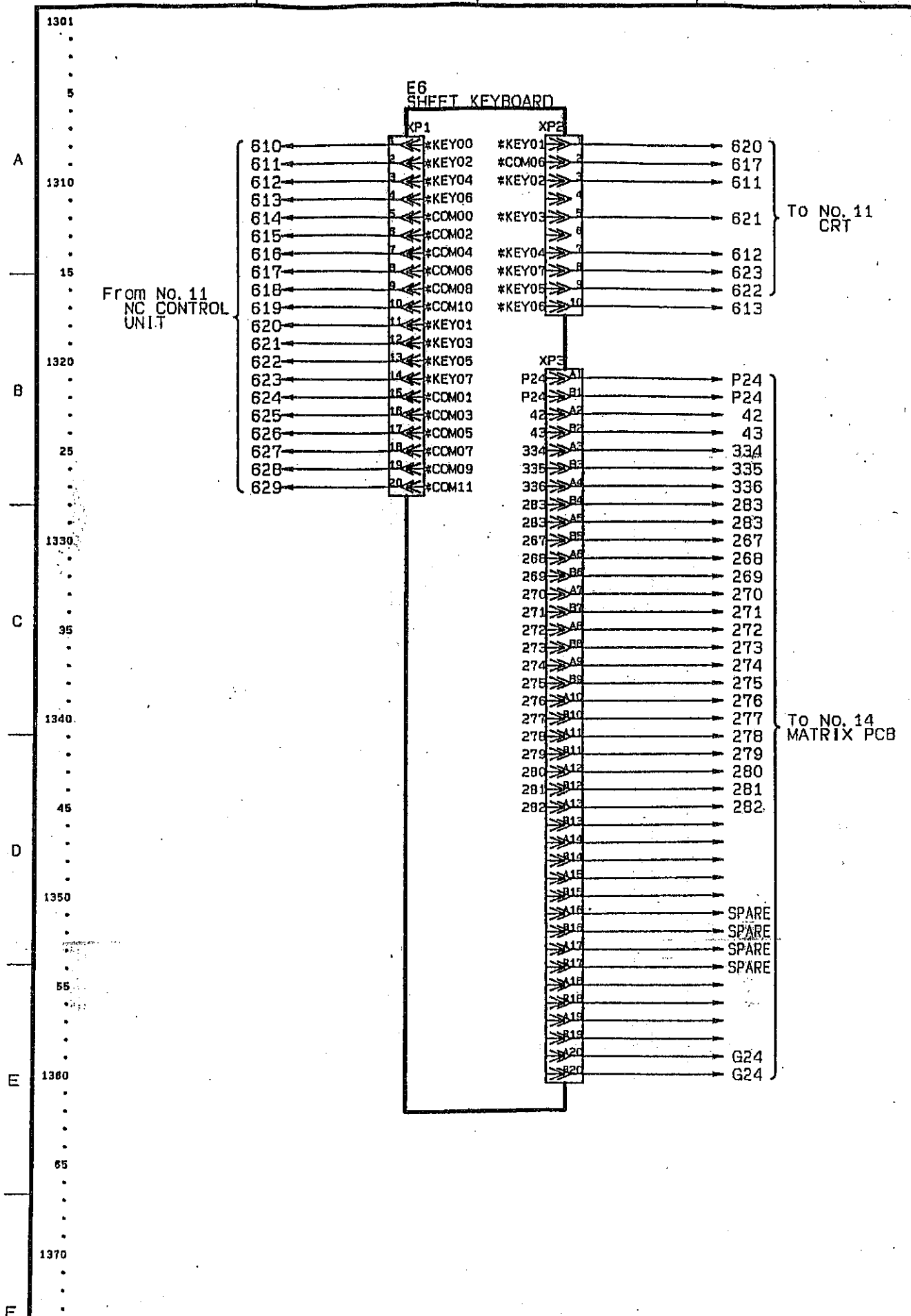

承認 APPROVED	検図 CHECKED	設計 DESIGNED	製図 DRAWN	第二図番 PRIMARY DWG. NO.	形式 MODEL	名作 NAME
		5942 KAMBE	6423 OZAWA	505EL0103A3	OGM-1224	SCHEMATIC DIAGRAM
				岡本工作機械製作所 OKAMOTO MACHINE TOOL WORKS, LTD	図番 DRAWING NO.	頁 PAGE
				3430		13

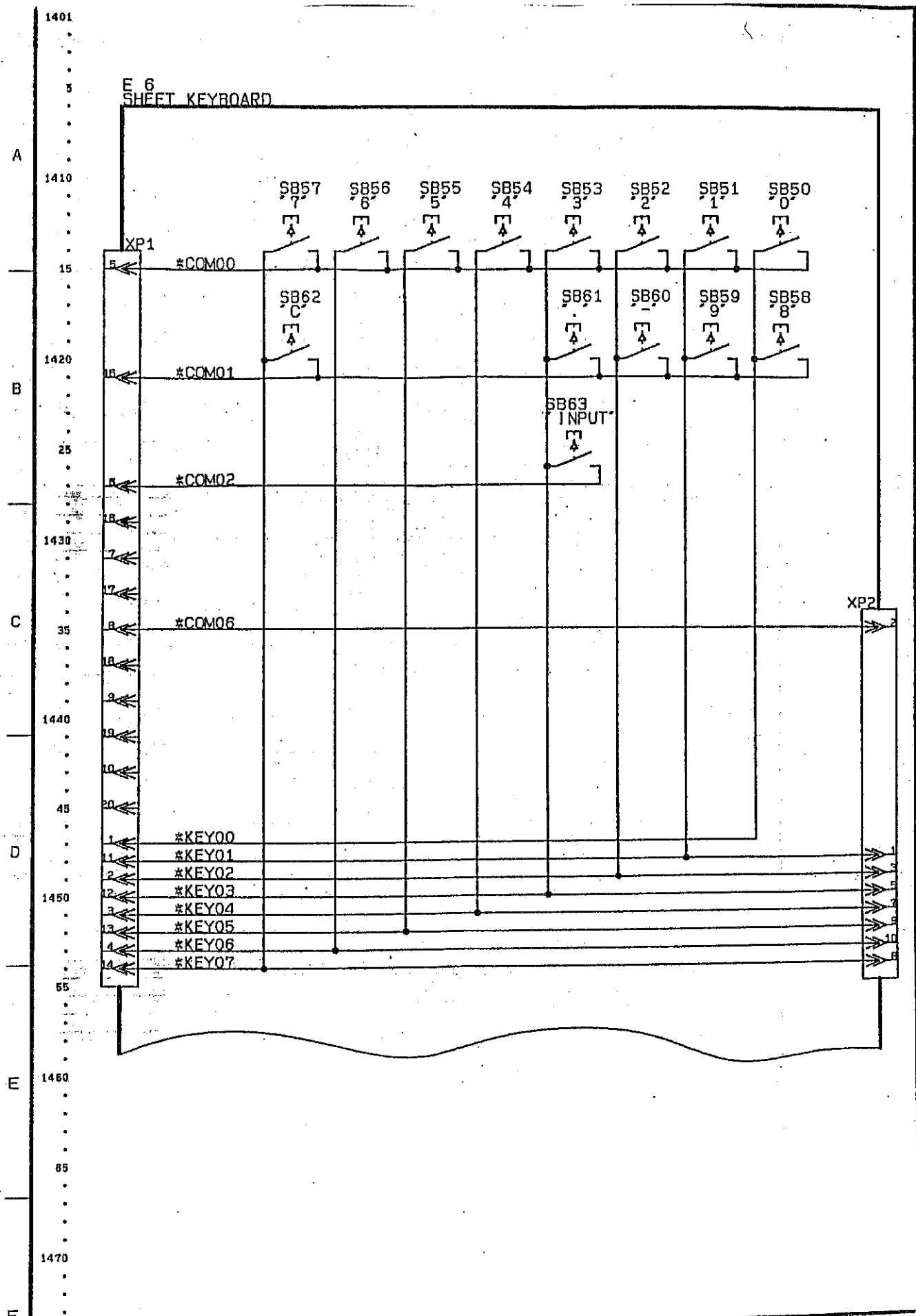

承認 APPROVED	換圖 CHECKED	設計 DESIGNED	製圖 DRAWN	第二圖號 PRIMARY DWG. NO. 505EL0104A3	形式 MODEL OGM-1224	名稱 NAME SCHEMATIC DIAGRAM		
		5942 KAMBE	5942 KAMBE	岡本工作機械製作所 OKAMOTO MACHINE TOOL WORKS, LTD.	分組コード CODE	圖番 DRAWING No.	頁 PAGE	
		931013	931013		3430		14	

E 6 SHEET KEYBOARD

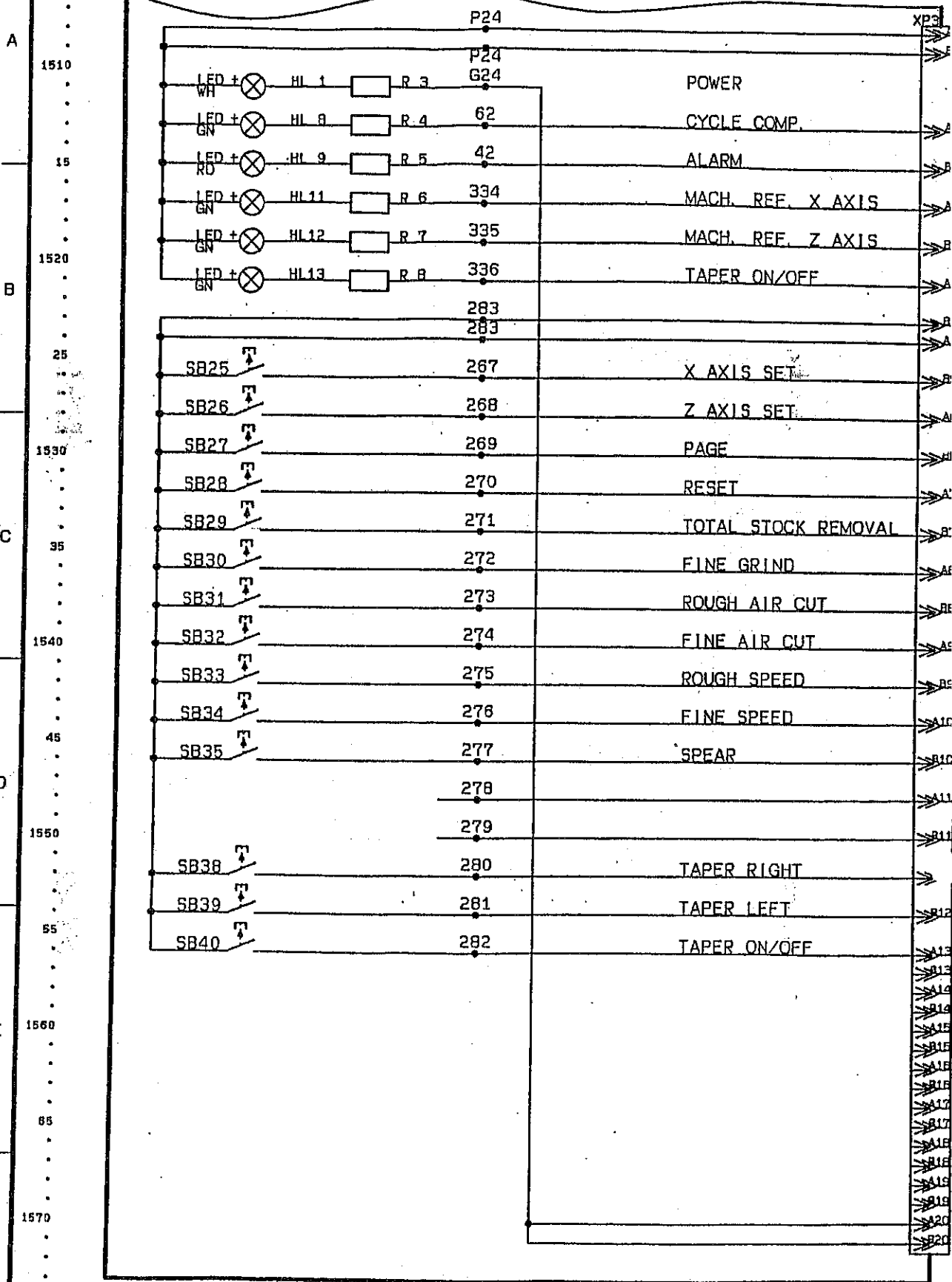

承認 APPROVED	検図 CHECKED	設計 DESIGNED	製図 DRAWN	第二図番 PRIMARY DWG. NO.	形式 MODEL	名符 NAME
		5942 KAMBE	5942 KAMBE	505EL0105A3	OGM-1224	SCHEMATIC DIAGRAM
岡本工作機械製作所 OKAMOTO MACHINE TOOL WORKS LTD.				分組コード C. CODE	図番 DRAWING NO.	頁 PAGE
				2120		15

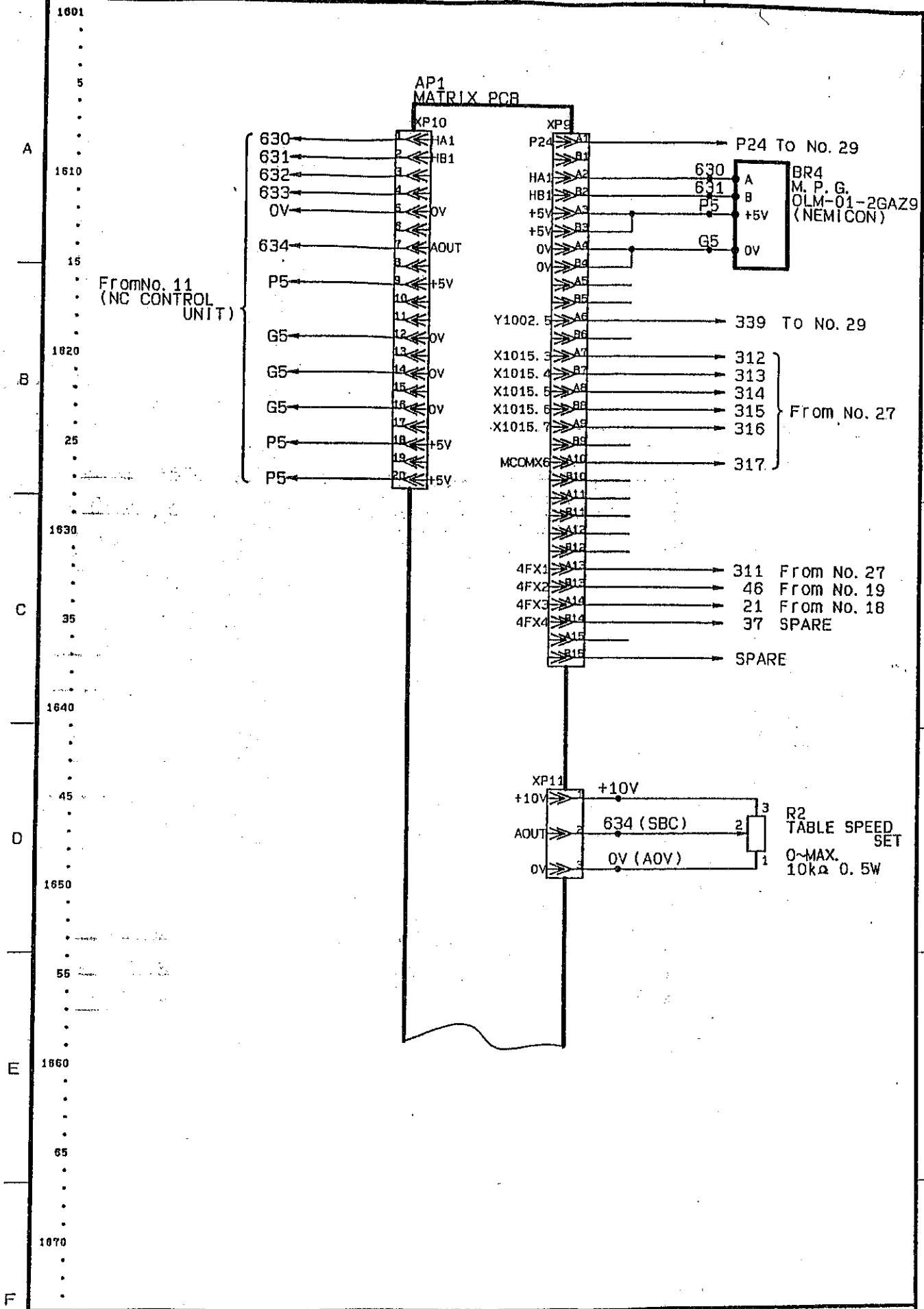

承認 APPROVED	検図 CHECKED	設計 DESIGNED	製図 DRAWN	第二図番 PRIMARY Dwg. No.	形式 MODEL	名件 NAME
		5942 KAMBE	5942 KAMBE	505EL0652A3	OGM-Series	SCHEMATIC DIAGRAM
		990127	990127	岡本工作機械製作所 OKAMOTO MACHINE TOOL WORKS, LTD.	図番 DRAWING No.	頁 PAGE
				3430		16

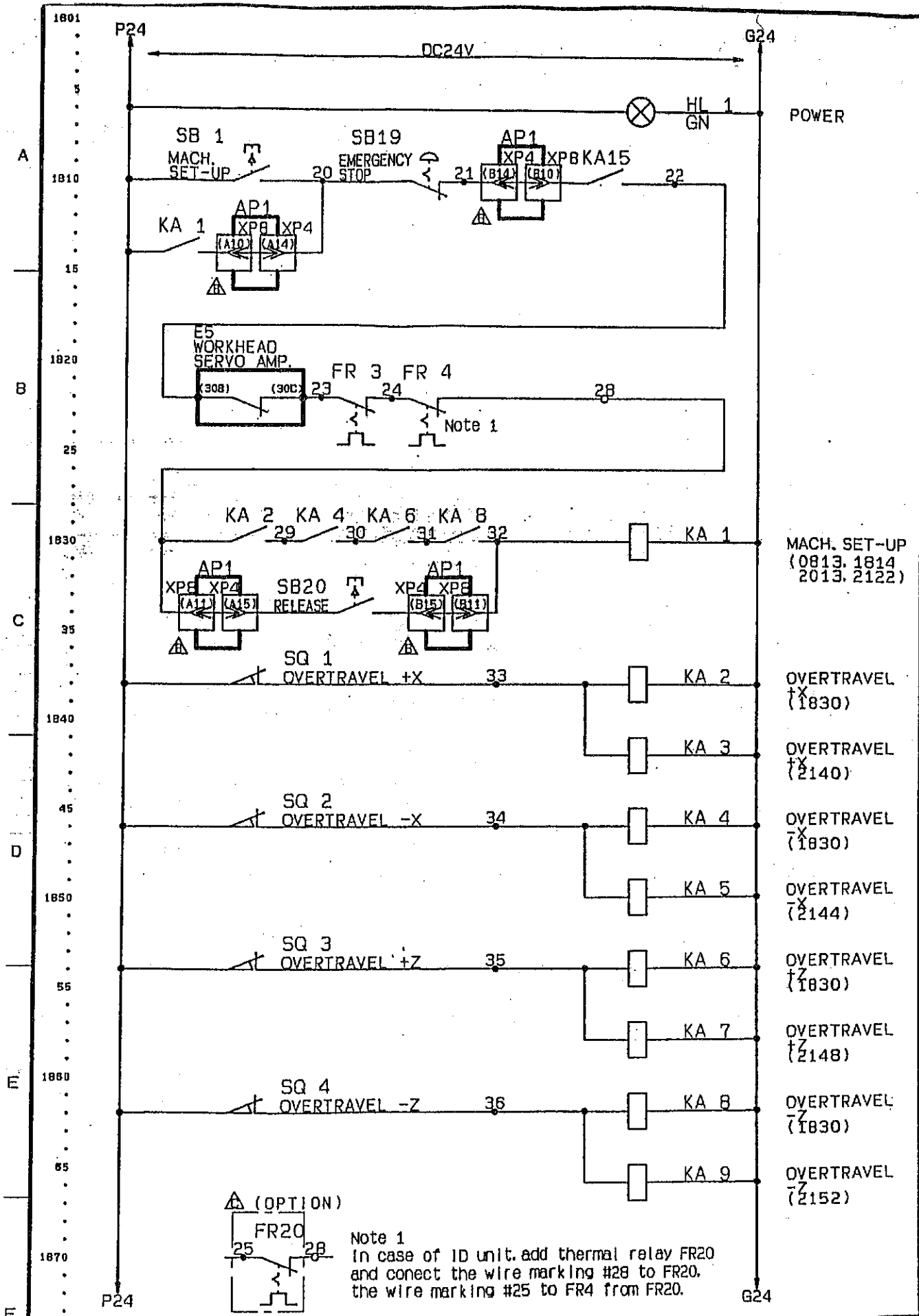

POWER

MACH. SET-UP
(0813, 1814, 2013, 2122)

OVERTRAVEL
+X (1830)

OVERTRAVEL
+Y (2140)

OVERTRAVEL
+X (1830)

OVERTRAVEL
+X (2144)

OVERTRAVEL
+Z (1830)

OVERTRAVEL
+Z (2148)

OVERTRAVEL
-Z (1830)

OVERTRAVEL
-Z (2152)

承認 APPROVED	検同 CHECKED	設計 DESIGNED	製図 DRAWN	第一図番 PRIMARY Dwg. No.	形式 MODEL	名 NAME
				505EL0108C3	OGM-Series	SCHEMATIC DIAGRAM
	5942 KAMBE	5942 KAMBE	5510 MATSUYAMA	岡本工作機械製作所 OKAMOTO MACHINE TOOL WORKS, LTD.	分類コード C. CODE 3430	図番 DRAWING No.
960905	930526	960905				頁 PAGE 18

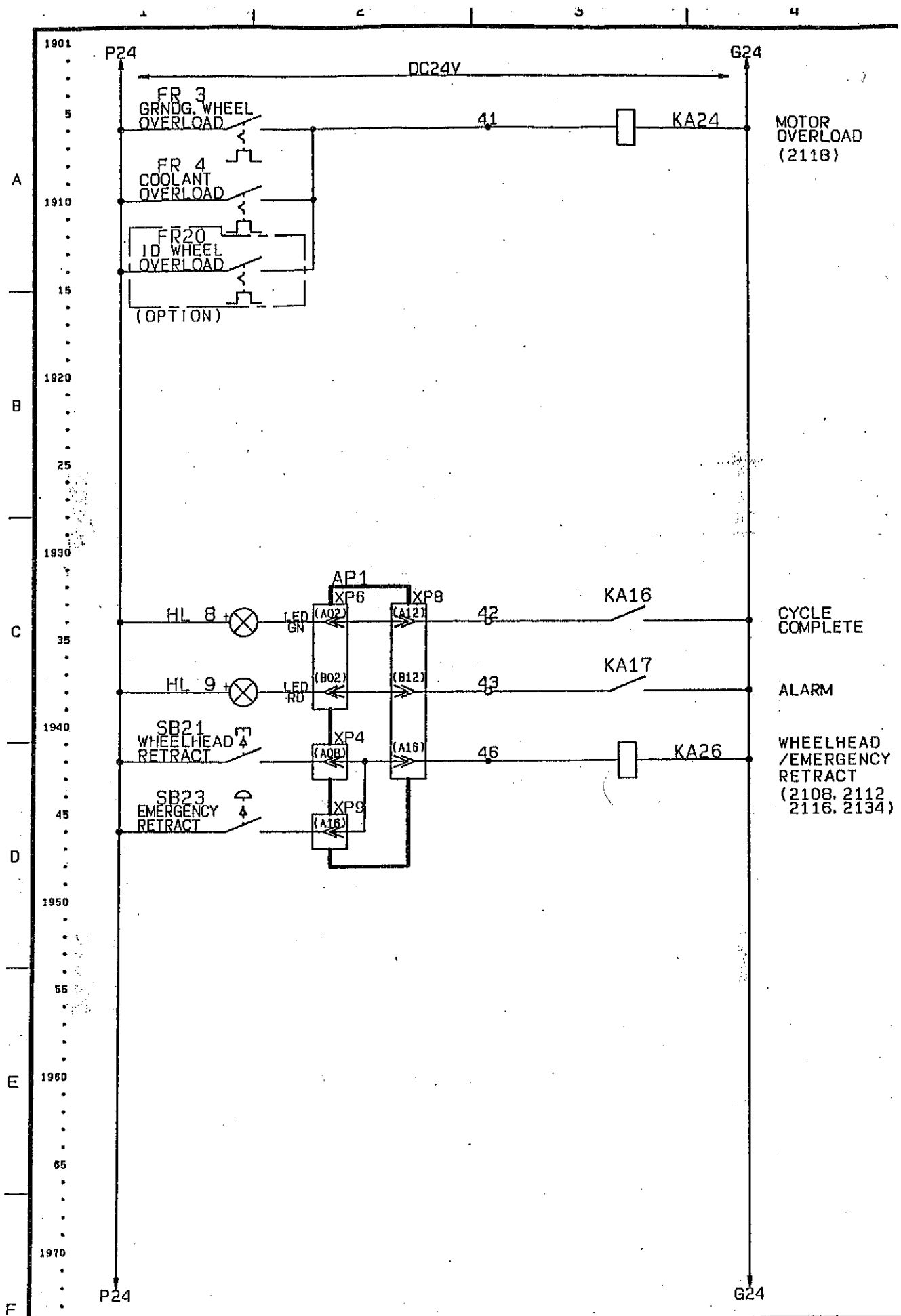

承認 APPROVED	検図 CHECKED	設計 DESIGNED	製図 DRAWN	第二図番 PRIMARY DWG. NO.	形式 MODEL	名符 NAME
		5942 KAMBE	5942 KAMBE	505EL0653A3	OGM-Series	SCHEMATIC DIAGRAM
岡本工作機械製作所 OKAMOTO MACHINE TOOL CO., LTD.				分組コード C. CODE	図番 DRAWING NO.	頁 PAGE
				2420		10

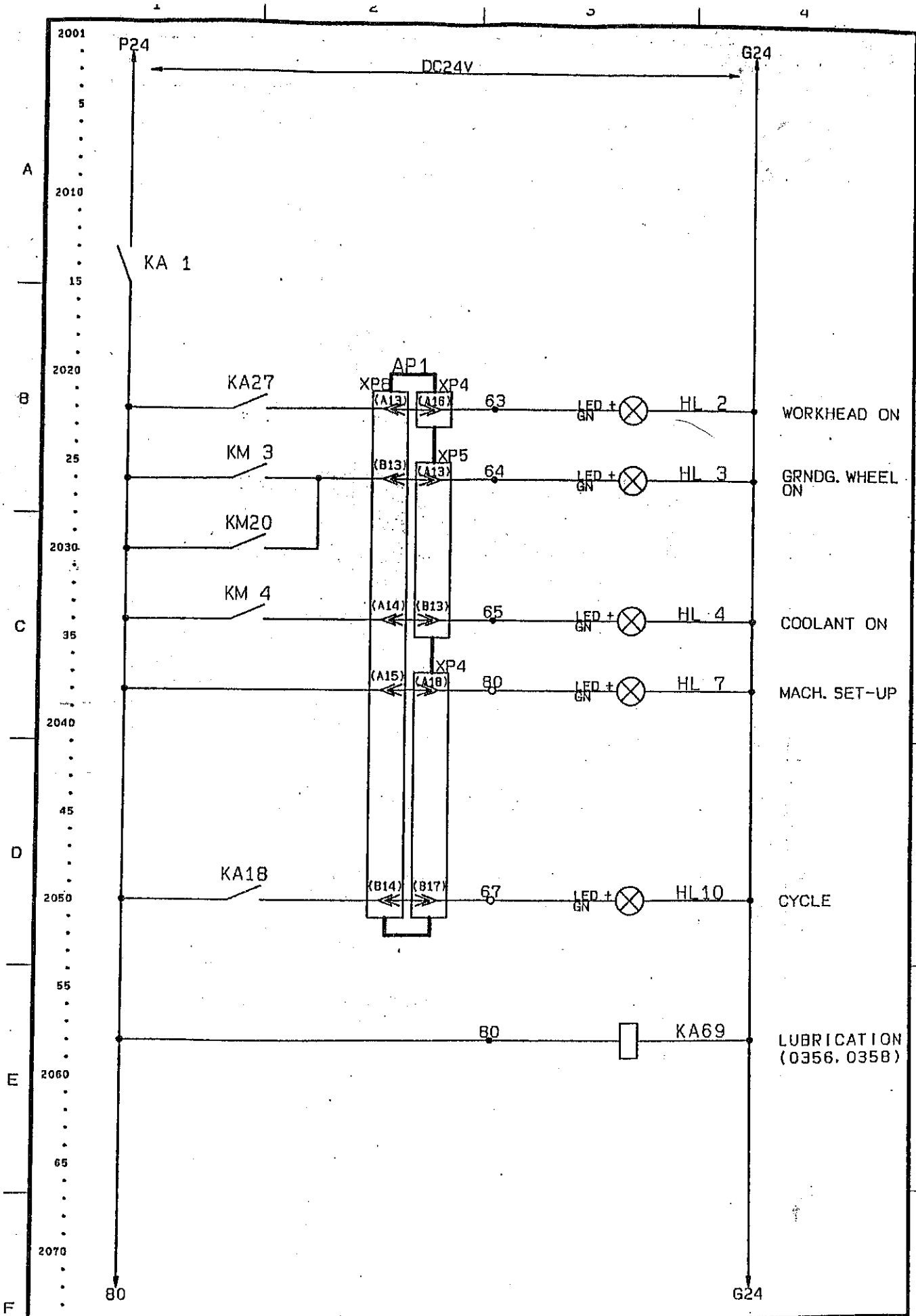

承認 APPROVED	検図 CHECKED	設計 DESIGNED	製図 DRAWN	第一図番 PRIMARY Des. No.	形式 MODEL	名 NAME
		5942 KAMRE	5942 KAMRE	505EL0654A3	OGM-Series	SCHEMATIC DIAGRAM
				図番 DRAWING No.	頁 PAGE	

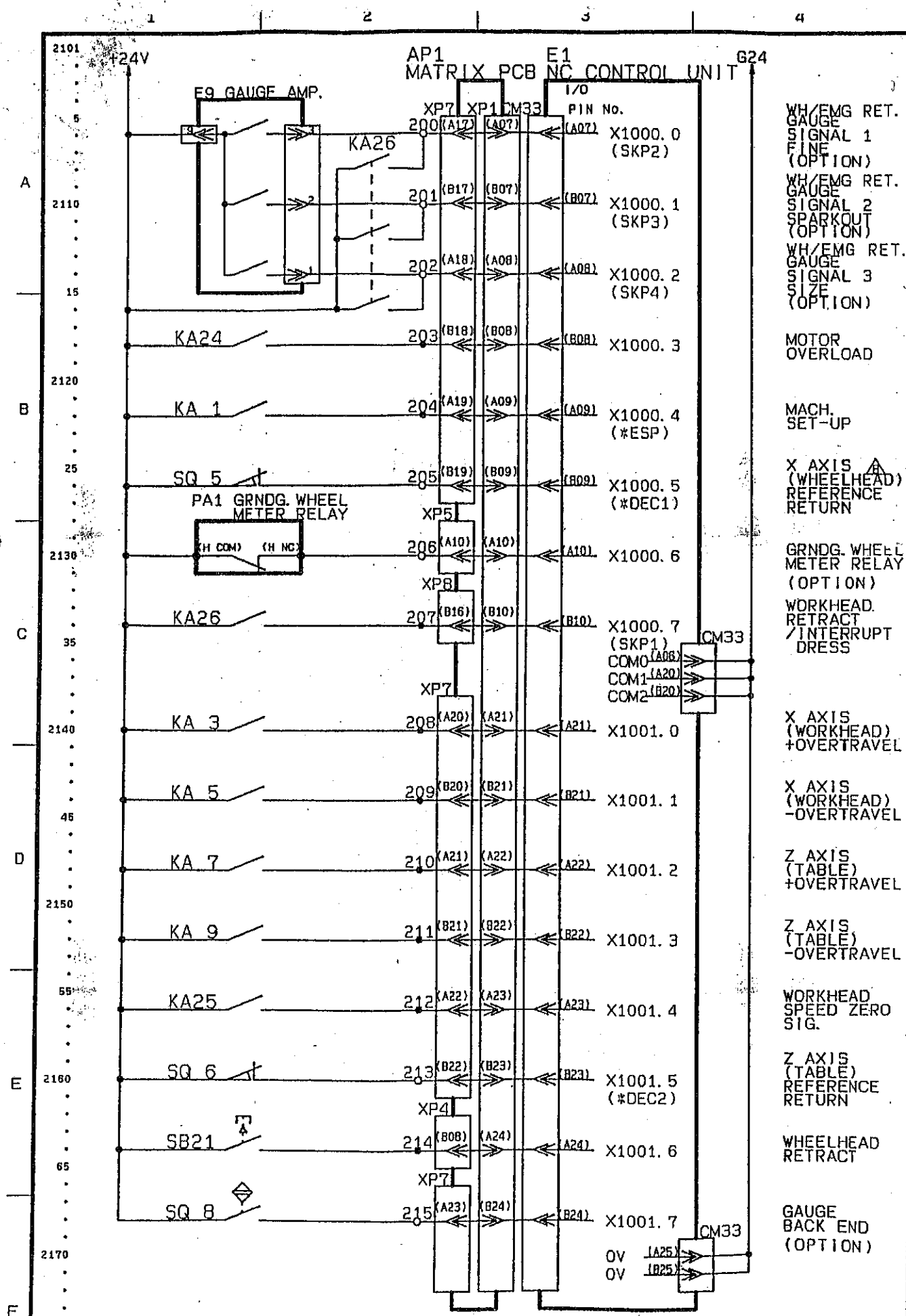

承認 APPROVED	検図 CHECKED	設計 DESIGNED	製図 DRAWN	第二図番 PRIMARY DWG. No.	形式 MODEL	名付 NAME
		5942 KAMBE	5942 KAMBE	505EL0655B3	OGM-Series	SCHEMATIC DIAGRAM
		5942 KAMBE	5942 KAMBE	岡本工作機械製作所 OKAMOTO MACHINE TOOL WORKS LTD	分組コード C.CODE 3110	図番 DRAWING No. PAGE 21

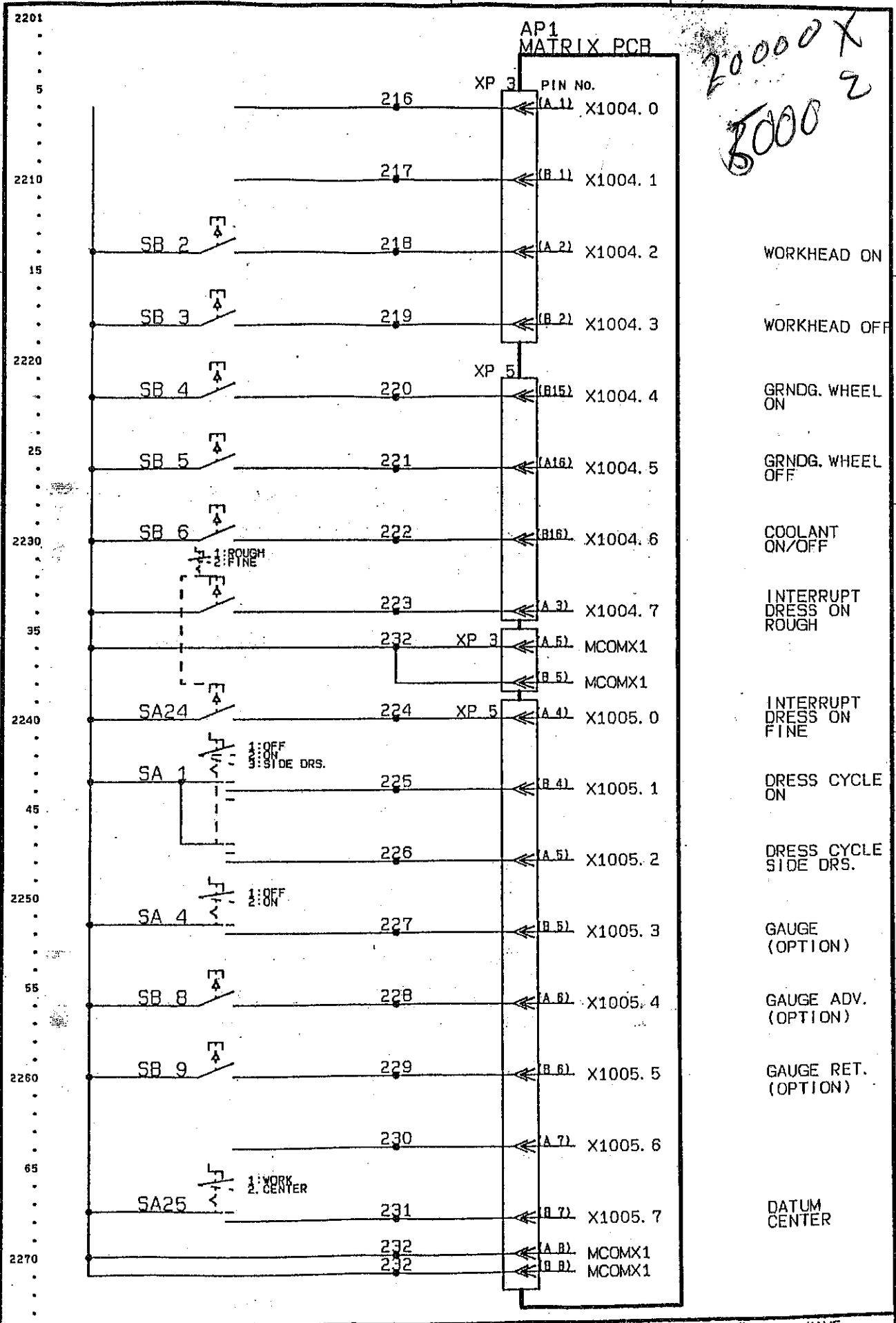

承認 APPROVED	検図 CHECKED	設計 DESIGNED	製図 DRAWN	第一図番 PRIMARY DWG. NO.	形式 MODEL	名 NAME
		5942 KAMBE	5942 KAMBE	505EL0656A3	OGM-Series	SCHEMATIC DIAGRAM
		990127	990127	岡本工作機械製作所 OKAMOTO MACHINE TOOL WORKS, LTD.	分類コード C. CODE 3440	図番 DRAWING NO. PAGE 22

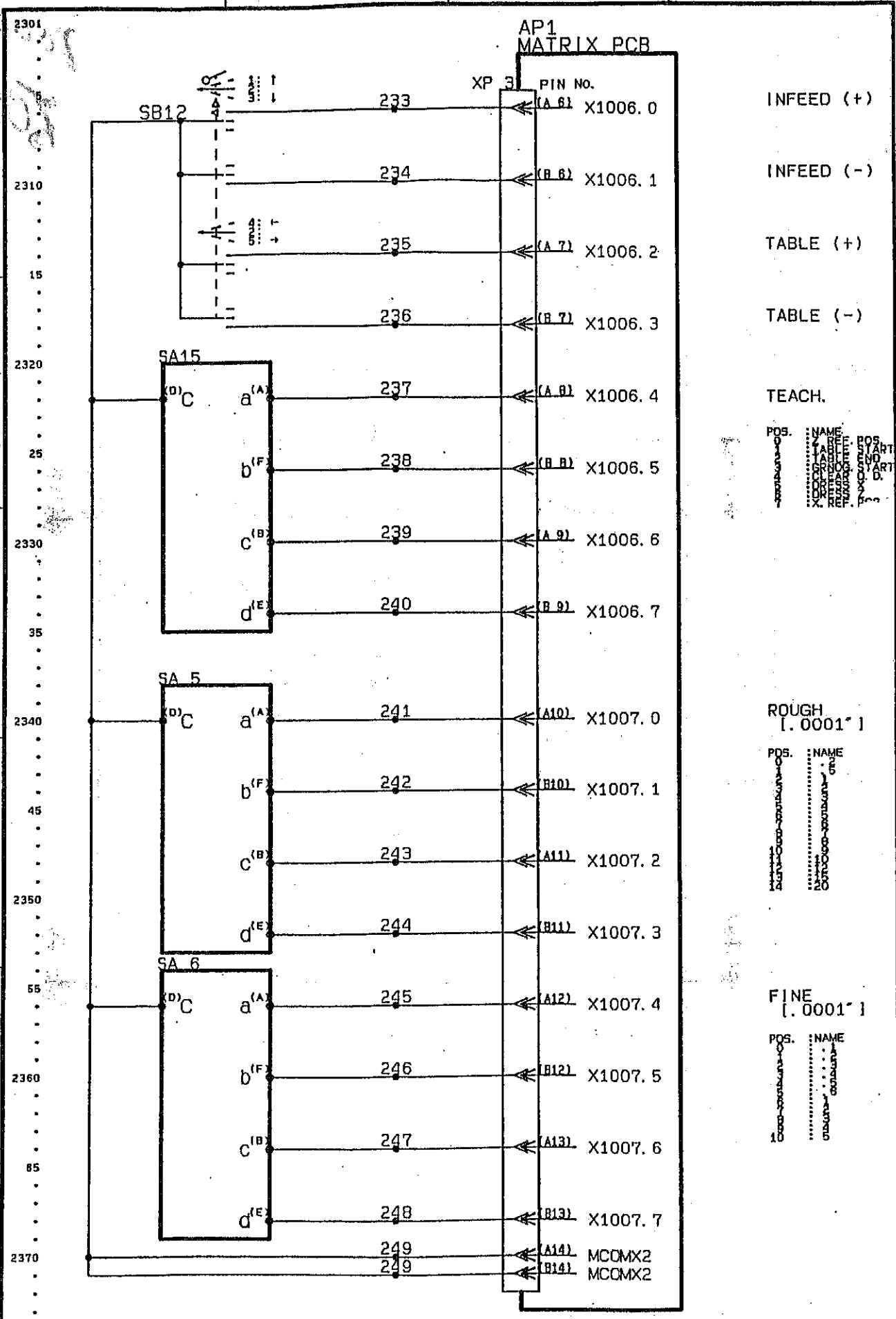

承認 APPROVED	検図 CHECKED	設計 DESIGNED	製図 DRAWN	原図番 PRIMARY DWG. No.	形式 MODEL	名作 NAME
		5942 KAMBE	5942 KAMBE	505EL0657A3	OGM-series	SCHEMATIC DIAGRAM
				岡本工作機械製作所	分類コード C.CODE	図番 DRAWING No. 頁 PAGE

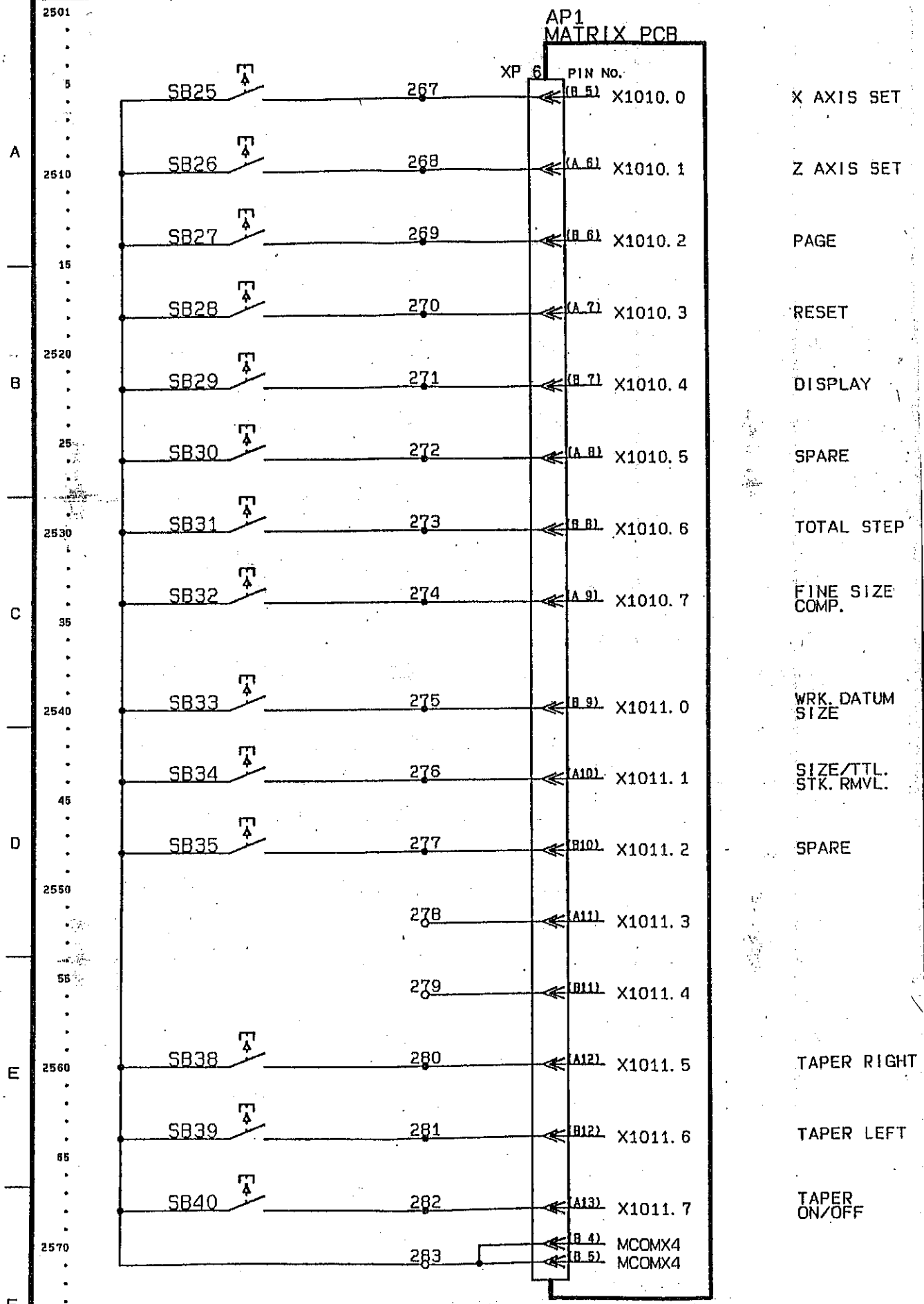

承認 APPROVED	検図 CHECKED	設計 DESIGNED	製図 DRAWN	第一図番 PRIMARY DWS. No.	形式 MODEL	名性 NAME
		5942 KAMBE	5942 KAMBE	505EL0659A3	OGM-series	SCHEMATIC DIAGRAM
岡本工作機械製作所				分類コード C.CODE	図番 DRAWING NO.	頁 PAGE

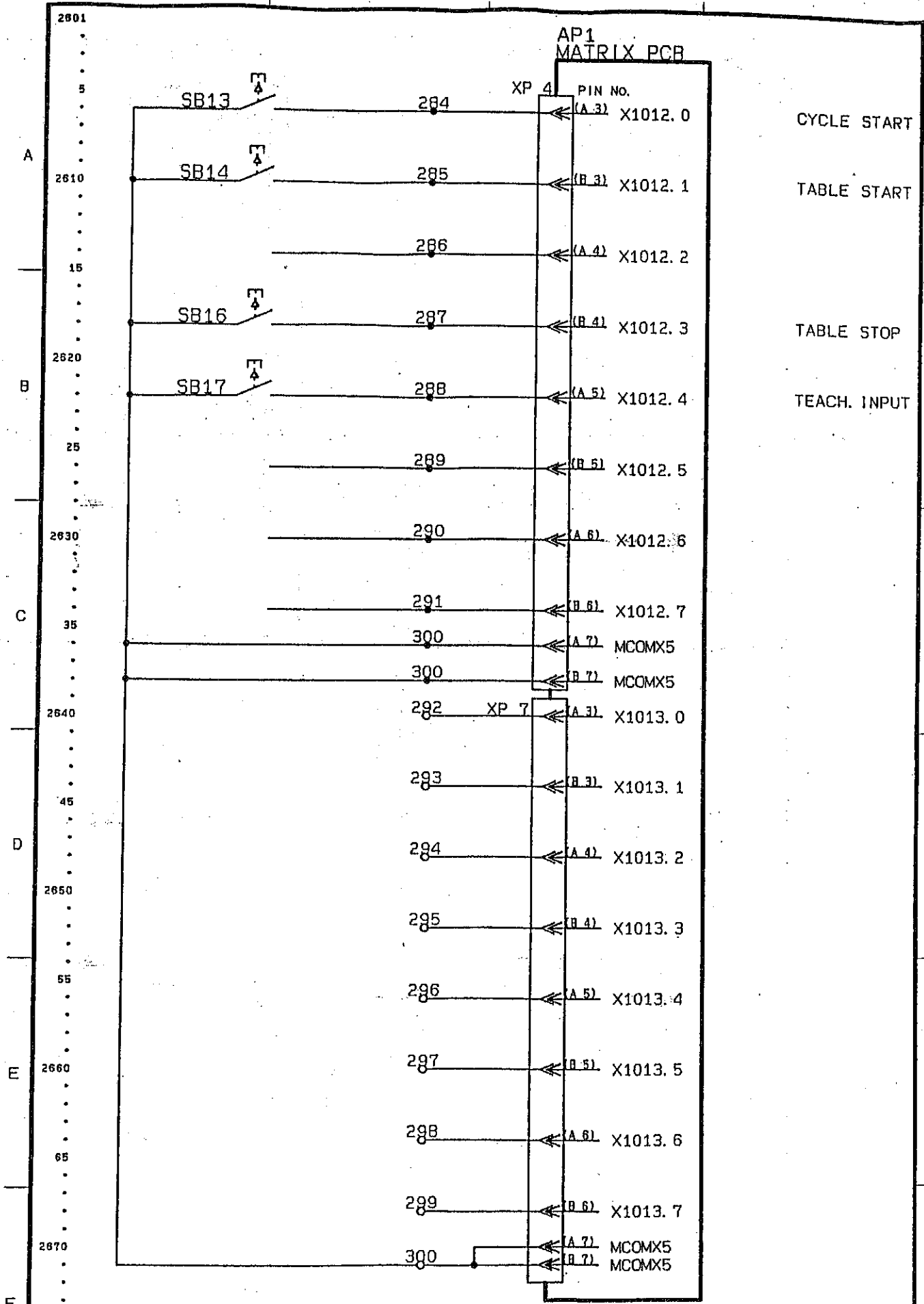

承認 APPROVED	検図 CHECKED	設計 DESIGNED	製図 DRAWN	第二図番 PRIMARY DWG. No.	形式 MODEL	名符 NAME
		5942 KAMBE	5942 KAMBE	505EL0660A3	OGM-Series	SCHEMATIC DIAGRAM
		990128	990128	岡本工作機械製作所 OKAMOTO MACHINE TOOL WORKS, LTD.	分類コード C.COE 3440	図番 DRAWING No. 頁 PAGE 26

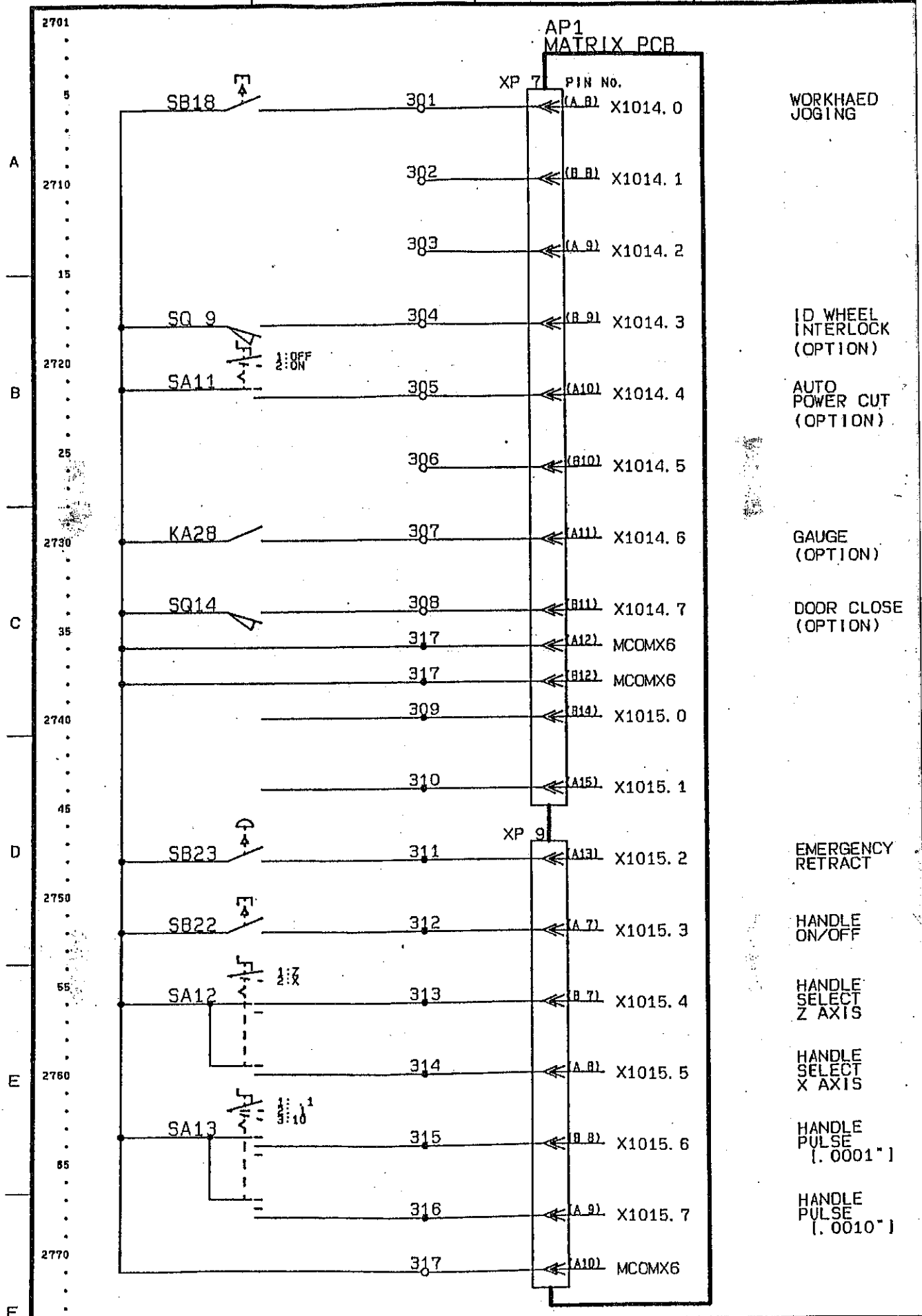

承認 APPROVED	検図 CHECKED	設計 DESIGNED	製図 DRAWN	第一図符 PRIMARY ENG. NO.	形式 MODEL	名 NAME
		5942 KAMBE	5942 KAMBE	505EL0661A3	OGM-Series	SCHEMATIC DIAGRAM
岡本工作機械製作所				分類コード CODE	図番 DRAWING NO.	頁 PAGE

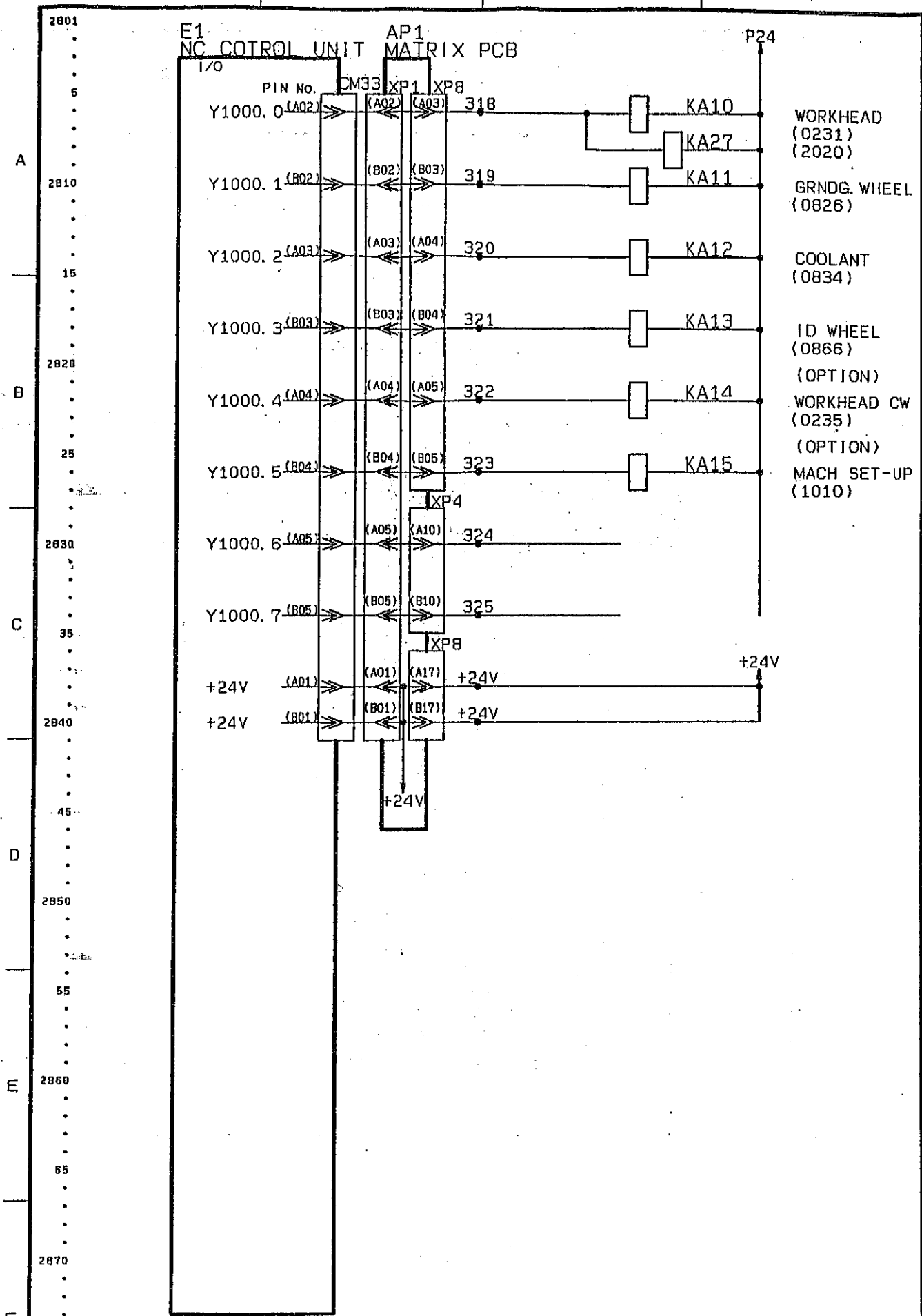

承認 APPROVED	検図 CHECKED	設計 DESIGNED	製図 DRAWN	第二図番 PRIMARY DWG. NO. 505EL0662A3	形式 MODEL OGM-Series	名称 NAME SCHEMATIC DIAGRAM
		5942 KAMBE	5942 KAMBE	岡本工作機械製作所 OKAMOTO MACHINE TOOL WORKS, LTD.	分類コード C. CODE 3450	図番 DRAWING No. PAGE 28
		990128	990128			

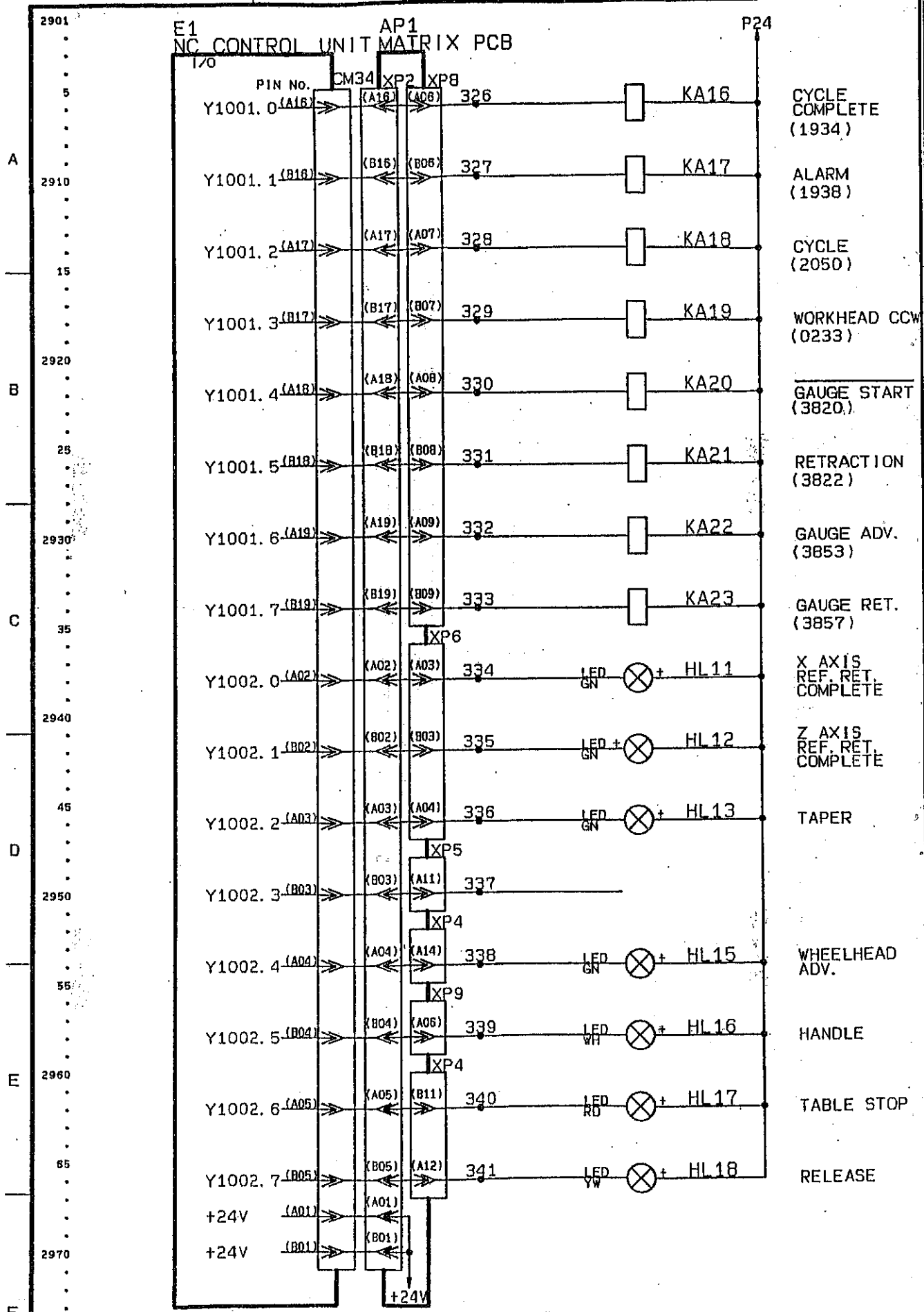

承認 APPROVED	検図 CHECKED	設計 DESIGNED	製図 DRAWN	第二図番 PRIMARY DWG. NO.	形式 MODEL	名 NAME
		5942 KAMBE	5942 KAMBE	505EL0663A3	OGM-Series	SCHEMATIC DIAGRAM
				岡本工作機械製作所	分類コード C.CODE	図番 DRAWING NO.
					2450	頁 PAGE

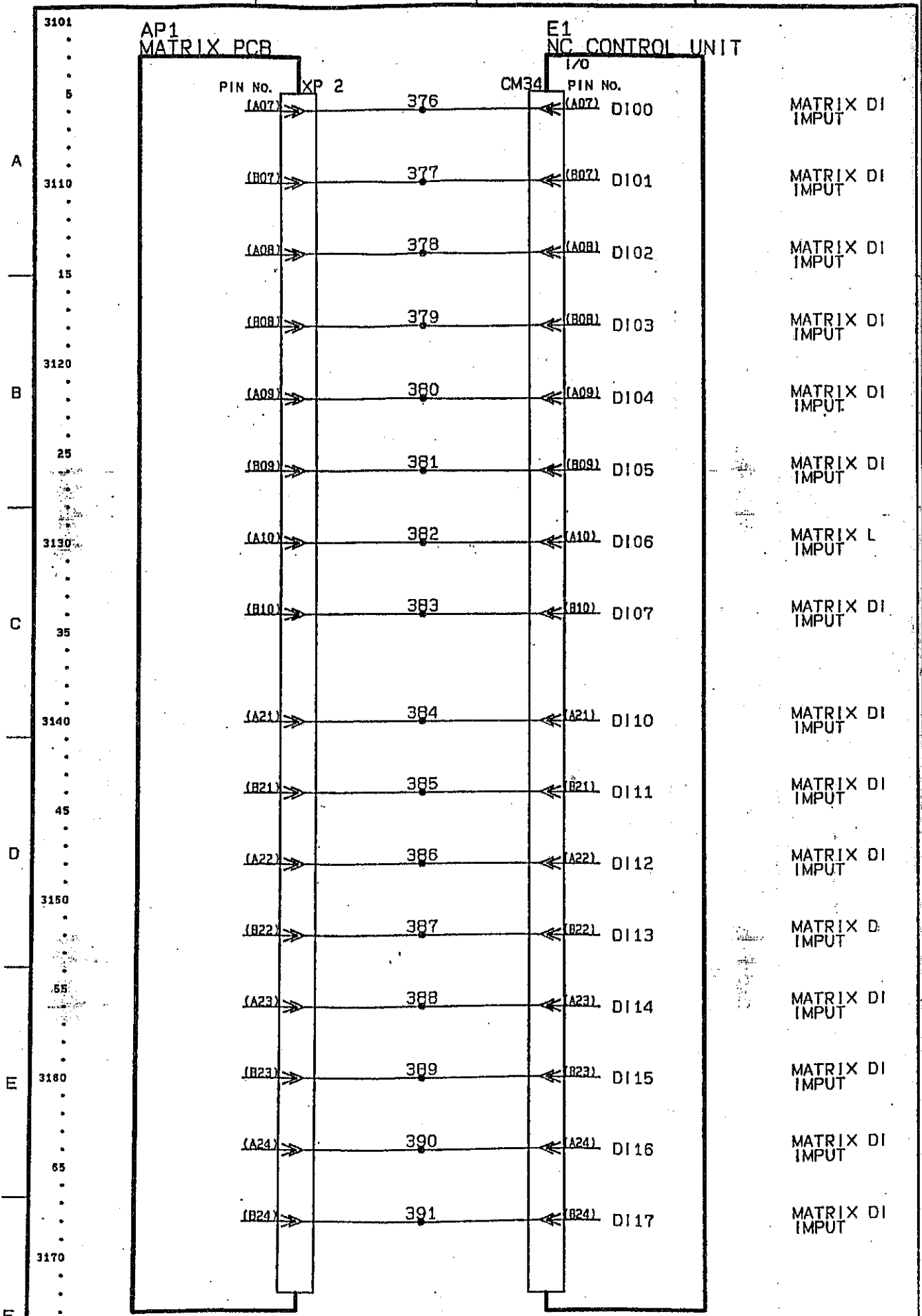

承認 APPROVED	検図 CHECKED	設計 DESIGNED	製図 DRAWN	第一図番 PRIMARY DNG. No.	形式 MODEL	名作 NAME
		5942 KAMBE	5942 KAMBE	505EL0121B3	OGM-series	SCHEMATIC DIAGRAM
岡本工作機械製作所				分図コード C. CODE	図番 DRAWING No.	頁 PAGE

A
B
C
D
E
F

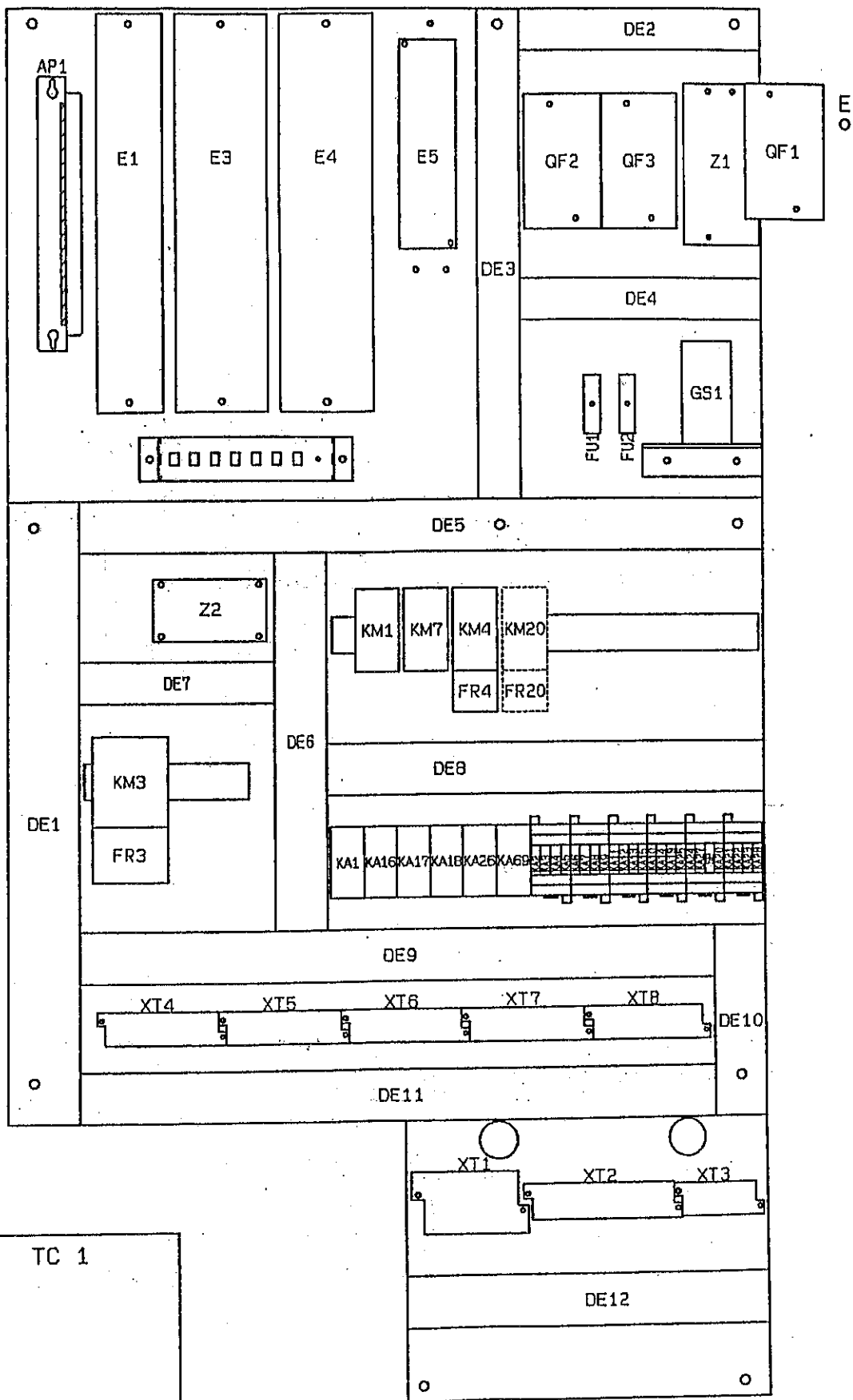

承認 APPROVED	検 CHECKED	図 DESIGNED	製 DRAWN	第二図番 PRIMARY DNG. No.	形式 MODEL	名称 NAME
	5942 KAMBE	5942 KAMBE	5510 MATSUYAMA	505EL0214C3	OGM-Series	INSTALLATION DRAWING (CONTROL ENCLOSURE)
960905	940318	960905		岡本工作機械製作所 OKAMOTO-MACHINE TOOL WORKS, LTD.	分組コード C. CODE 3490	図番 DRAWING NO. PAGE 32

A

B

C

D

E

F

510

400

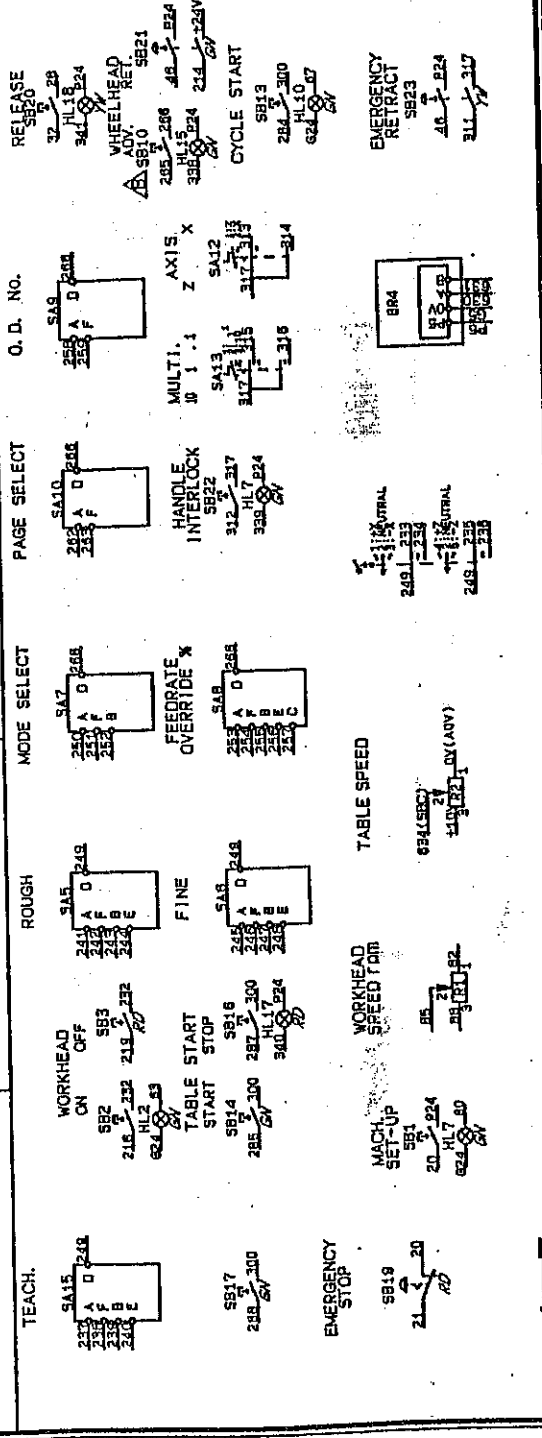
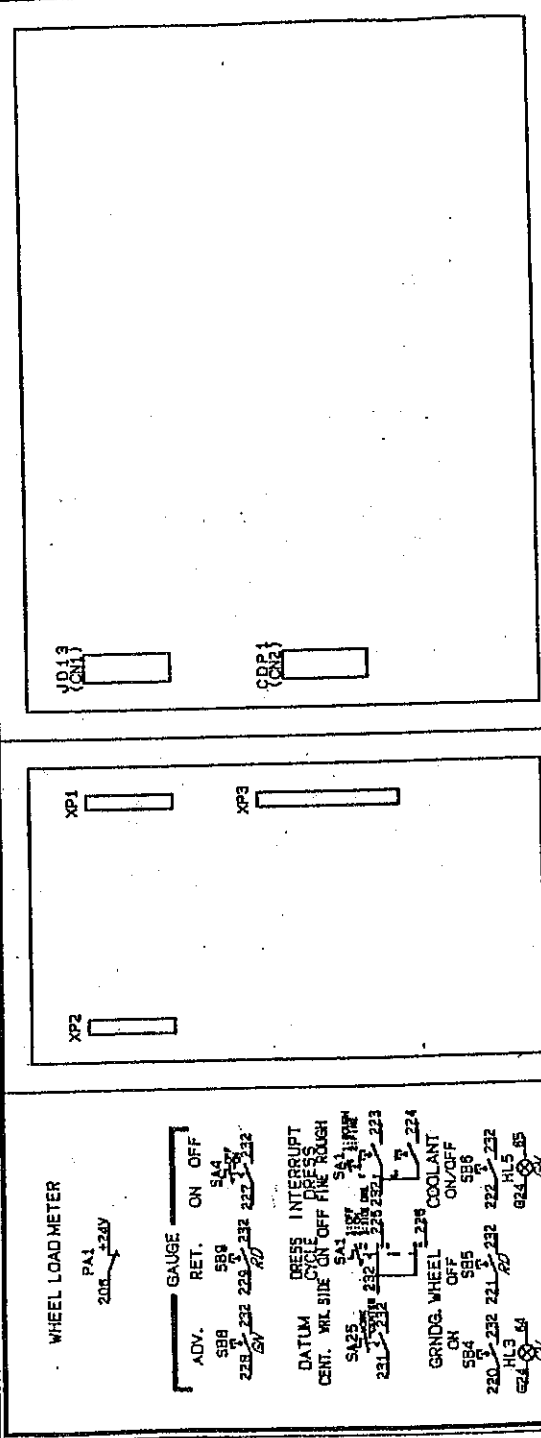

承認 APPROVED	検同 CHECKED	設計 DESIGNED	製図 DRAWN	第一設計 PRIMARY ENG. NO.	形式 MODEL	名付 NAME
		5942 KAMBE	5942 KAMBE	505EL0664B3	OGM-Series	INTERCONNECTION DIAGRAM (CONTROL PANEL)
				岡本工作機械製作所	分類コード C CODE	図番 DRAWING NO.
						頁 PAGE 33

A B C D E F

機番符号	機番名称	備考
M 1	WORKHEAD	
M 3	GRNDG. WHEEL	
M 4	COOLANT	OPTION
M 5	MAG. SEPARATOR	OPTION
M 7	X-AXIS	
M10	LUBRICATION	
M11	Z-AXIS	
M20	ID WHEEL	OPTION
SQ 1	OVERTRAVEL +X	
SQ 2	OVERTRAVEL -X	
SQ 3	OVERTRAVEL +Z	
SQ 4	OVERTRAVEL -Z	
SQ 5	REFERENCE RETURN (X)	
SQ 6	REFERENCE RETURN (Z)	
SQ 8	GAUGE BACK END	OPTION
SQ 9	ID INTERLOCK	OPTION
SQ14	DOOR CLOSE	OPTION
SB18	WORKHEAD JOG	
SB22	HANDLE INTERLOCK	
SB23	EMERGENCY RETRACT	

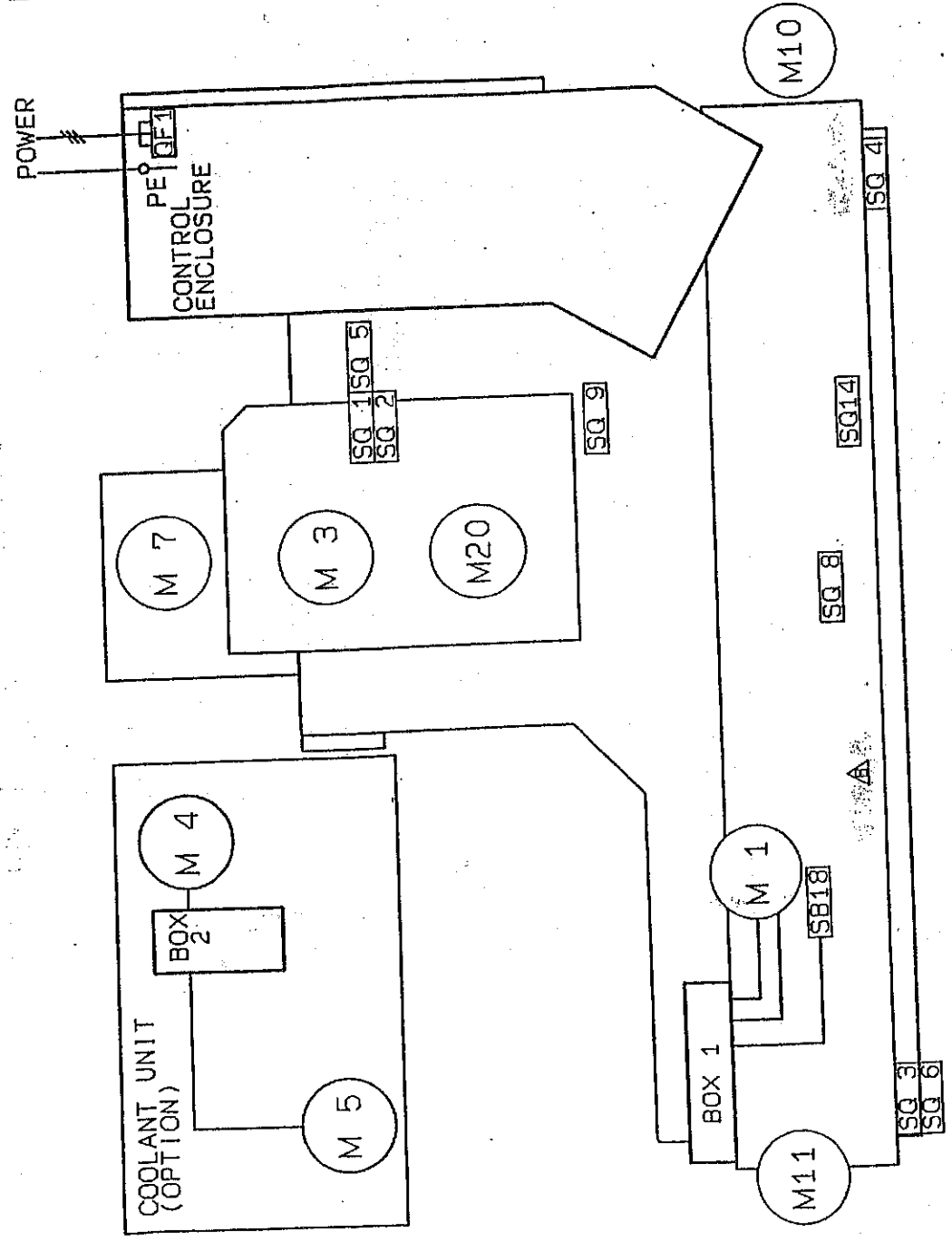

承認 APPROVED	検閲 CHECKED	設計 DESIGNED	製図 DRAWN	第二図階 PRIMARY DWG. No.	形式 MODEL	名作 NAME
		5942	5942	505EL0666B3	OGM-series	INSTALLATION DRAWING
岡本工作機械製作所				分類コード	図番	DRAWING No.
						頁 PAGE

A B C D E F

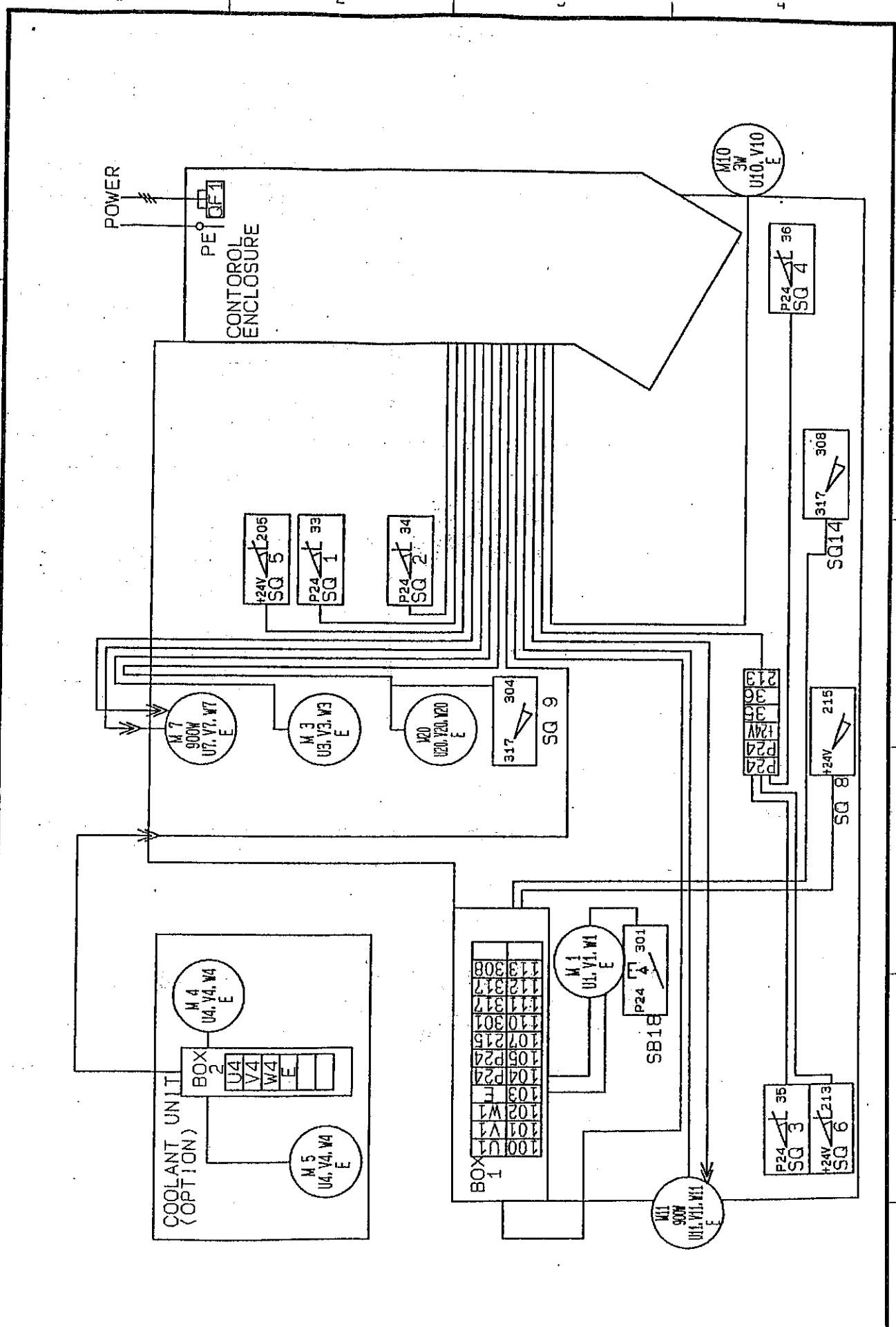

承認 APPROVED	検図 CHECKED	設計 DESIGNED	製図 DRAWN	第二図時 PRIMARY DWG. NO.	形式 MODEL	名称 NAME
		5942 KAMBE	5942 KAMBE	505EL0667A3	OGM-Series	INTERCONNECTION DIAGRAM
				岡本工作機械製作所 OKAMOTO MACHINE TOOL WORKS LTD.	分類コード C.CODE 2510	図番 DRAWING NO.
						頁 PAGE 36

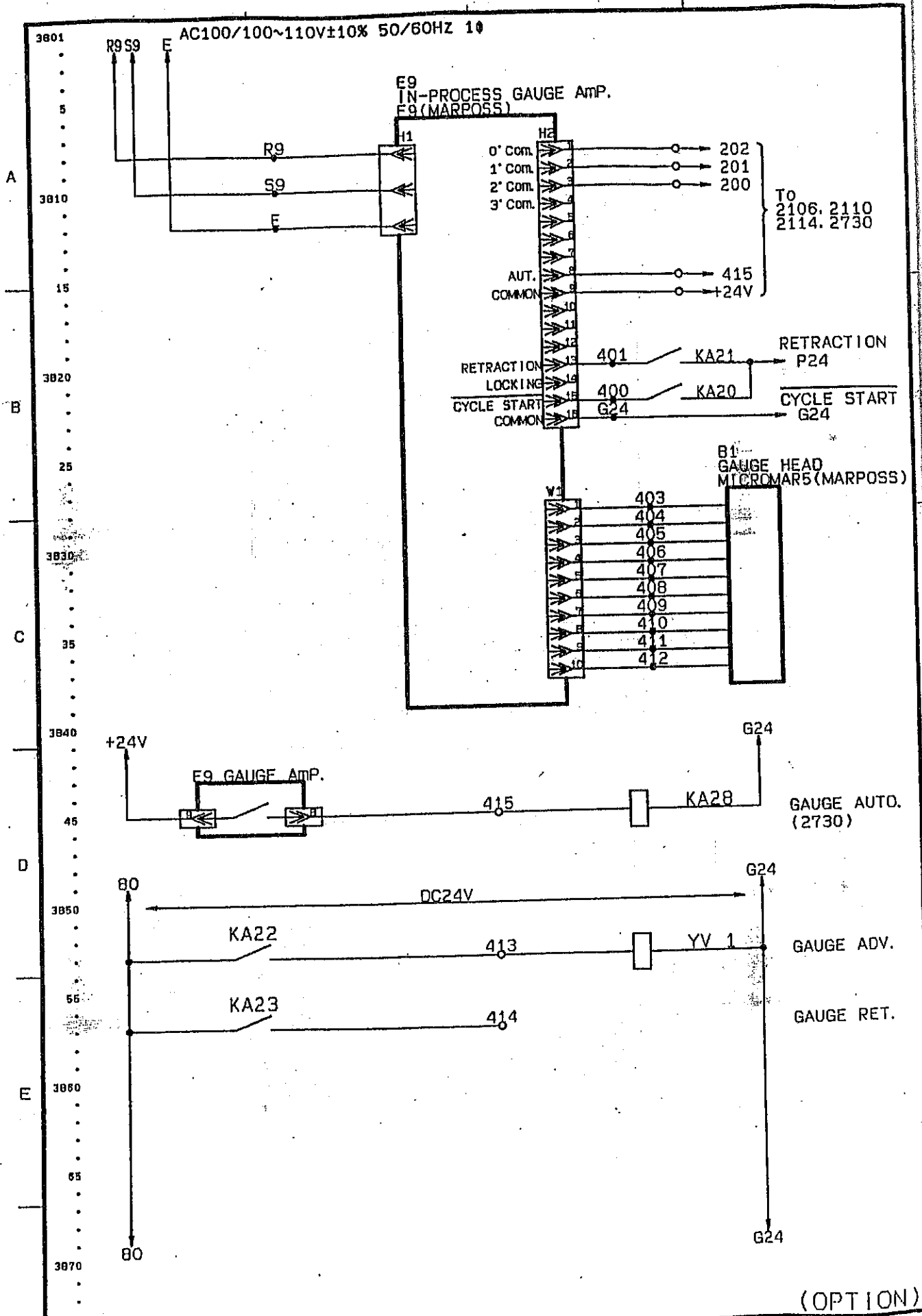

(OPTION)

承認 APPROVED	検図 CHECKED	設計 DESIGNED	製図 DRAWN	第一図計 PRIMARY DWG. No.	形式 MODEL	名付 NAME
		5942	5942	505EL0602A3	OGM-Series	SCHEMATIC DIAGRAM
		KAMBE	KAMBE	岡本工作機械製作所	分組コード C. CODE	DRAWING No. 頁 PAGE
						28

11. HOW TO SET THE WHEEL

11-1 Notes on Grinding Wheel

In grinding machines, wheels are used by running at high speeds and therefore great care must be given to their handling. A little your careless mistakes may cause damage to the wheel, and in some cases, this will lead to a serious accident. So always try to care much about correct handling of grinding wheels.

- NOTES
- Before mounting the grinding wheel to the wheel flange, check its appearance, and then carefully check the surface all through for inversely affecting damage and crack due to handling.
 - Slightly hit on the face side of the grinding wheel using a wooden hammer to check for clear sound. If there is a crack or break, an unclear sound will be emitted, so that, do not use such wheels. ▶ See Fig. 11-1.
 - Be certain that a label showing the wheel specifications is attached on both face sides of the wheel.

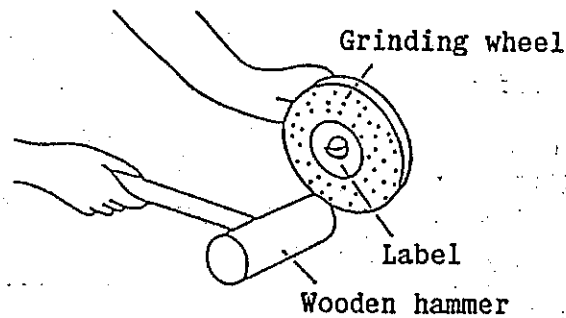

Fig. 11-1 Appearance Check of the Wheel

1. Mounting the wheel flange

- 1) Check the taper hole and wheel clamp face of the wheel flange for nick or gouge and adhesion of dust.
- 2) Assemble a wheel flange unit as shown in Fig. 11-2, except the balance piece. For fastening screws, try and tighten them diagonally by turns.

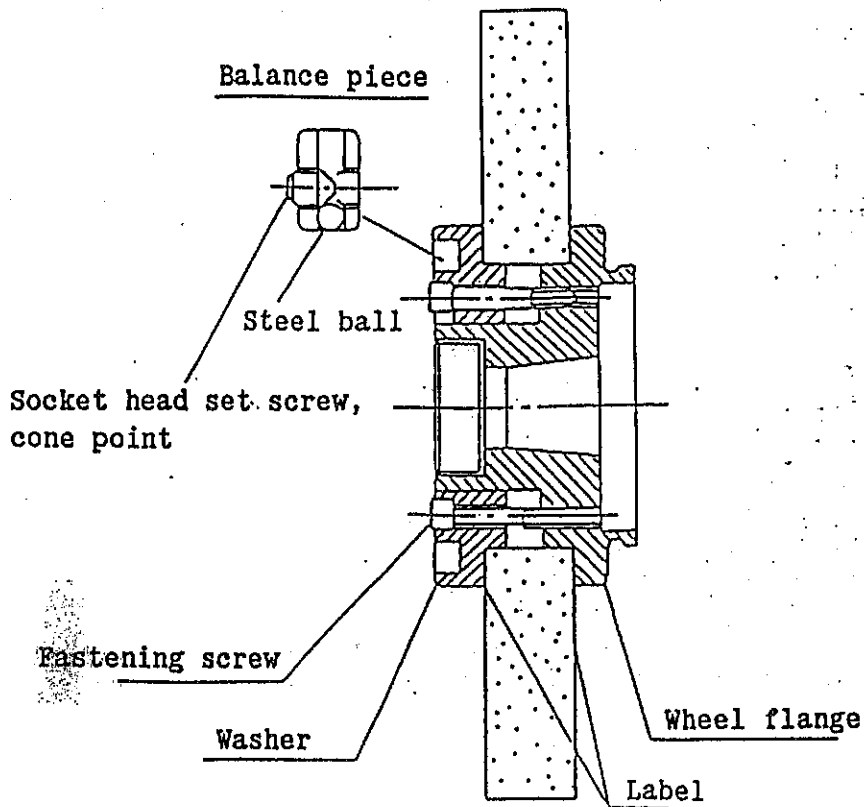

Fig. 11-2 Assembly of Wheel Flange Unit

2. Mounting the wheel flange unit onto the wheel spindle

- 1) Clean up the tapered portion of the wheel spindle to remove all dust. Screw the fastening nut as shown in Fig. 11-3 (left-handed thread, turns counterclockwise).
- 2) Put the wrench on the notch of the nut, and slightly hit thereon with a wooden hammer.

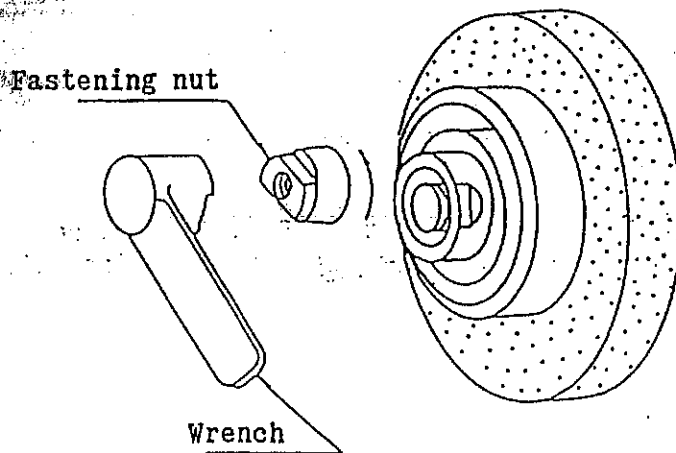

Fig. 11-3 Mounting onto the Wheel Spindle

3. Dismounting the wheel flange unit from the wheel spindle

- 1) Place the wrench on the fastening nut, slightly hit it clockwise to loosen and remove the nut. ▶ See Fig. 11-3.
- 2) Set the extraction nut to the screw thread of the wheel flange, and screw it clockwise until coming in contact with the tip of the spindle thread. ▶ See Fig. 11-4.
- 3) Put the wrench on the notch of the nut, and slightly hit thereon to remove the flange unit from the spindle taper.

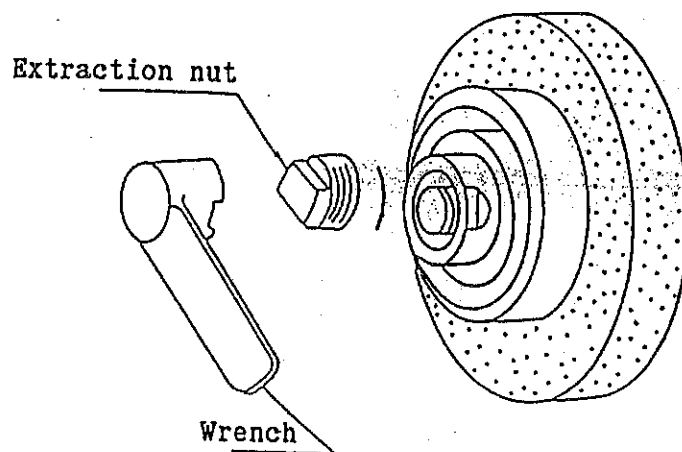

Fig. 11-4 Dismounting from the wheel spindle

4. Test run upon mounted the wheel

- 1) When running the spindle after mounting the wheel, the wheel cover must be closed.

NOTES - When starting the spindle, to provide against an unexpected wheel breakage, do not stand toward the direction wherein it will scatter.

- Turn the driving switch to ON and OFF several times, not to ON at once, so that the wheel spindle may increase speed.

- 2) The wheel should be idled for more than 3 minutes, and check the its face side for run-out and the machine for vibration noise during this time.

NOTE: The wheels must be idled for more than 3 minutes when mounted new ones, and even for used ones, for more than 1 minute.

11-2 How to Adjust the Balance

The wheel must be balanced. If this should not occur, chatter marking will be left on the ground surface, and machine accuracy and function will also be affected, vibrating the machine. To adjust the balance for the wheel unit mounted to the flange, the balancer and special arbor as shown below are provided as options.

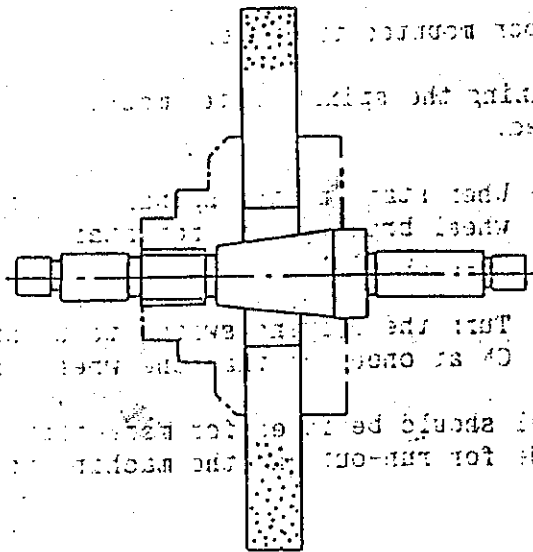
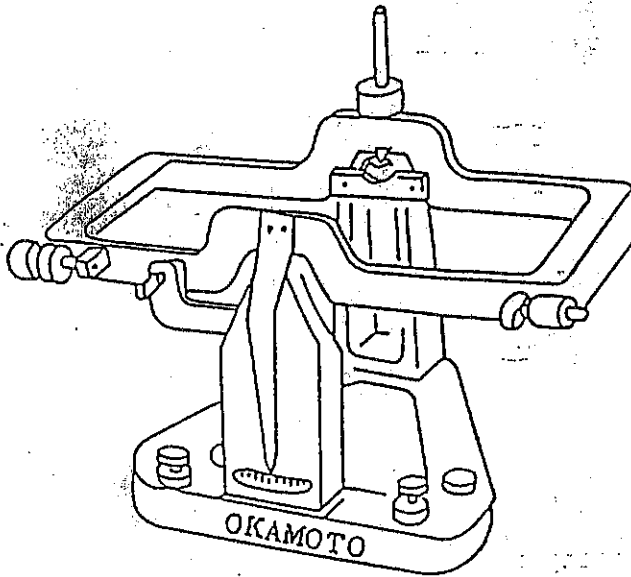
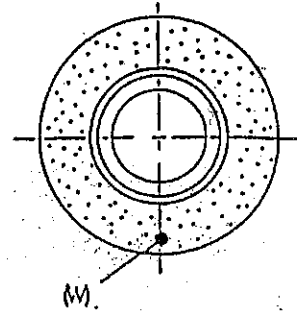
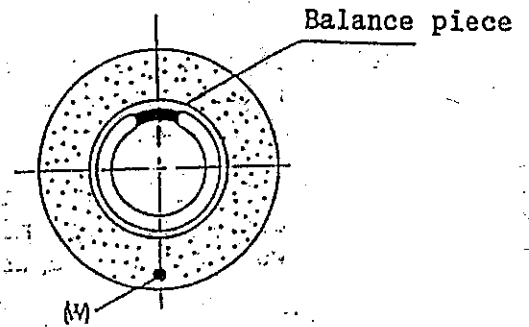

Fig. 11-5 Balancer and Special Arbor

- (1) Install the balance on the sturdy surface plate where is not exposed wind.
- (2) Mount the wheel to the wheel flange - leave balance pieces removed.
- (3) Mount the flange unit, and carry out dressing until run-out of its circumference has been eliminated.
- (4) Remove the wheel flange from the wheel spindle, and put it into the arbor to set them on the balancer.
- (5) The most heaviest portion will be oriented down, then put a mark on that point (W) with a chalk, etc.



- (6) Fit a balance piece on the position opposed to W.



- (7) Tilt the wheel flange by 90° to check to see which side is heavier, side fitted the balance piece or side of W.

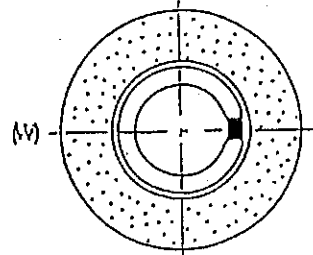

- (8) If the side of W is heavier, fit two balance pieces to adjust so that the angle (A) will be the same as the unbalanced amount as shown below.

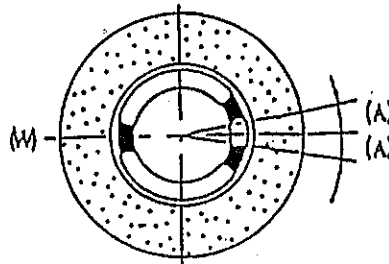

- (9) If the of W is lighter, fit them as shown below.

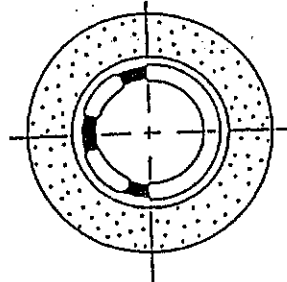

- (10) Change the position of the flange unit at angular intervals of 90° to check for balance.

NOTES - It is necessary to check the balance as the outside diameter becomes small, due to the structural change, even if well adjusted at the beginning.

- After using with the coolant, it is necessary to run the machine dryly for a few minutes to well remove the coolant, and then to work out the adjustment.

- The balancer requires a good sensitivity, so that, check its sensitivity in normal use and it is essential to make repairs if it becomes wrong.

11-3 Dressing and Truing

At the time mounted a new wheel, its circumference is slightly eccentric. The operation to restore correct cylindrical surface for that using a diamond tool is called truing. In addition, the operation to build sharp cutting edges anew using a diamond tool, when the sharpness of the wheel was lowered as a result of dulling and loading due to grinding, is called dressing. In most cases, these two are together called dressing in general, so that, we also call them dressing here.

1) Mounting the dresser

The diamond tool is mounted at a bevel angle of 5° to 10° as viewed from the wheel side, or 15° to 20° as viewed from the wheel top. If the diamond wears due to the repeated dressing, turn the diamond tool so that its sharp face may come in contact with the wheel. This enables you to always keep the tip of the diamond tool sharp. Dressing by the worn diamond will lower the grinding efficiency, causing dulling or glazing to the wheel surface.

2) Dressing conditions

The infeed amount of the diamond tool is to be $\phi 0.0004$ to $\phi 0.0008$ inches. As to the infeed speed, it is necessary to select the proper value according to the grinding roughness and efficiency. In general, it is to be 0.016 inches (rough grinding) to 0.004 inches (fine grinding) every time a wheel turn is completed. Continue dressing until emitting a continuous sound over the wheel surface. ▶ See Table 11-1.

Table 11-3 Dressing (Reference Values)

Dressing	Infeed speed	Infeed amount	No. of infeed times	No. of spark out times
Rough Grinding	200~500 mm/min	$\phi 0.01-0.02\text{mm}$	2 ~ 3	1 ~ 2
	7.9~20inch/min	$\phi 0.0004-$ $\phi 0.0008$ inch		
Fine Grinding	100~200 mm/min	$\phi 0.01-\phi 0.02\text{mm}$	2 ~ 3	1 ~ 2
	4~8 inch/min	$\phi 0.0002-$ $\phi 0.0004$ inch		

CONTENTS

	PAGE
1. FRONT VIEW.....	1
2. REAR VIEW.....	2
3. FRAME ASSEMBLY	3~8
4. GRINDING HEAD ASSEMBLY 1/2	9~12
5. GRINDING HEAD ASSEMBLY 2/2	13~18
6. TABLE TRAVERSE ASSEMBLY	19~22
7. WORK HEAD ASSEMBLY 1/2.....	23~26
8. WORK HEAD ASSEMBLY 2/2.....	27~30
9. WHEEL GUARD ASSEMBLY	31~34
10. SPINDLE ASSEMBLY.....	35~36
11. TAIL STOCK ASSEMBLY	37~40
12. TABLE ASSEMBLY 1/2	41~44
13. TABLE ASSEMBLY 2/2	45~52
14. PIPE ARRANGEMENT ASSEMBLY.....	53~56
15. CONTROL BOX ASSEMBLY.....	57~60
16. ELECTRICAL ASSEMBLY	61~62
17. NAME PLATE 1/2.....	63~66
18. NAME PLATE 2/2.....	67~68
19. COOLANT SYSTEM ASSEMBLY	69~70

FRONT VIEW

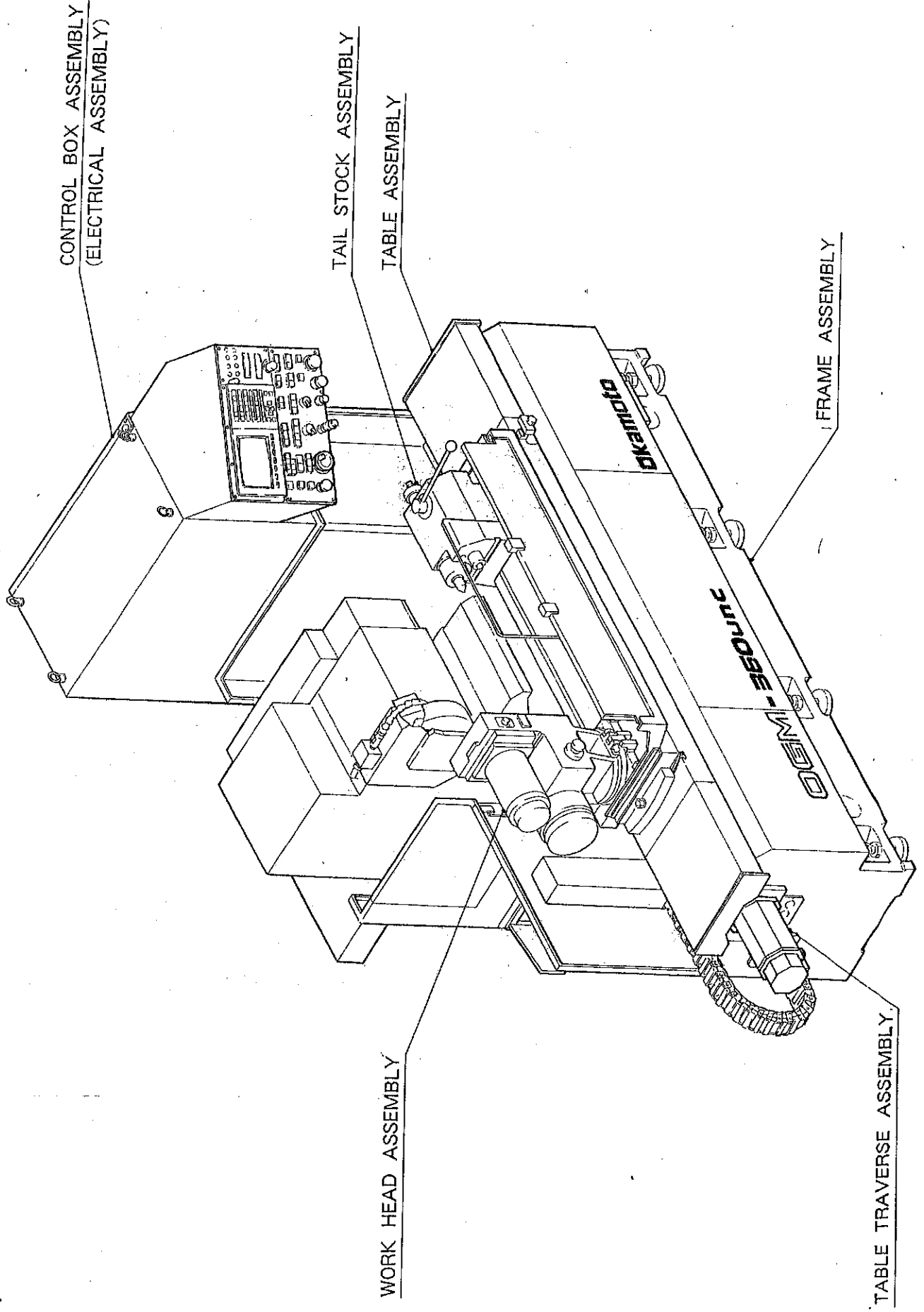

REAR VIEW

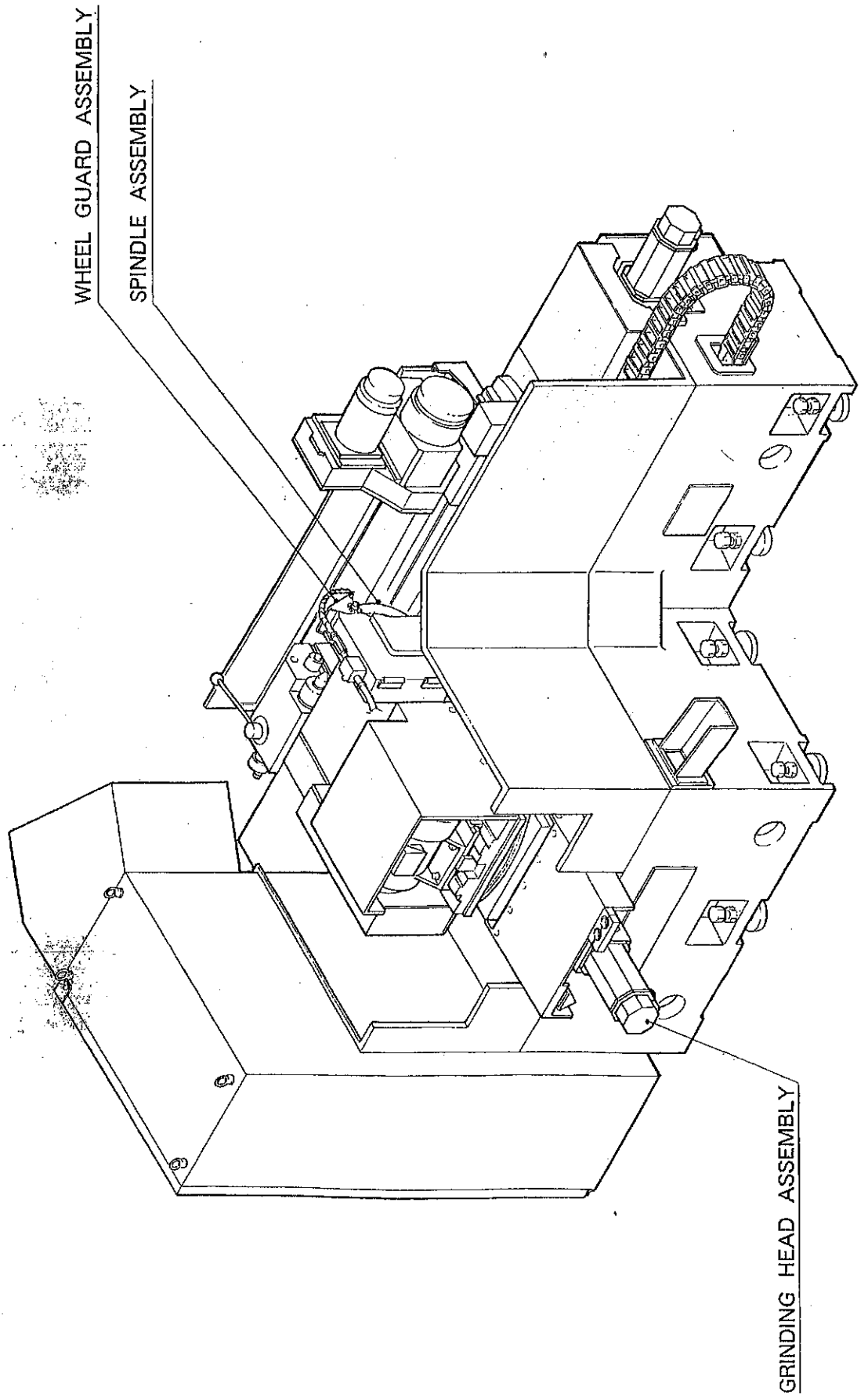

FRAME ASSEMBLY

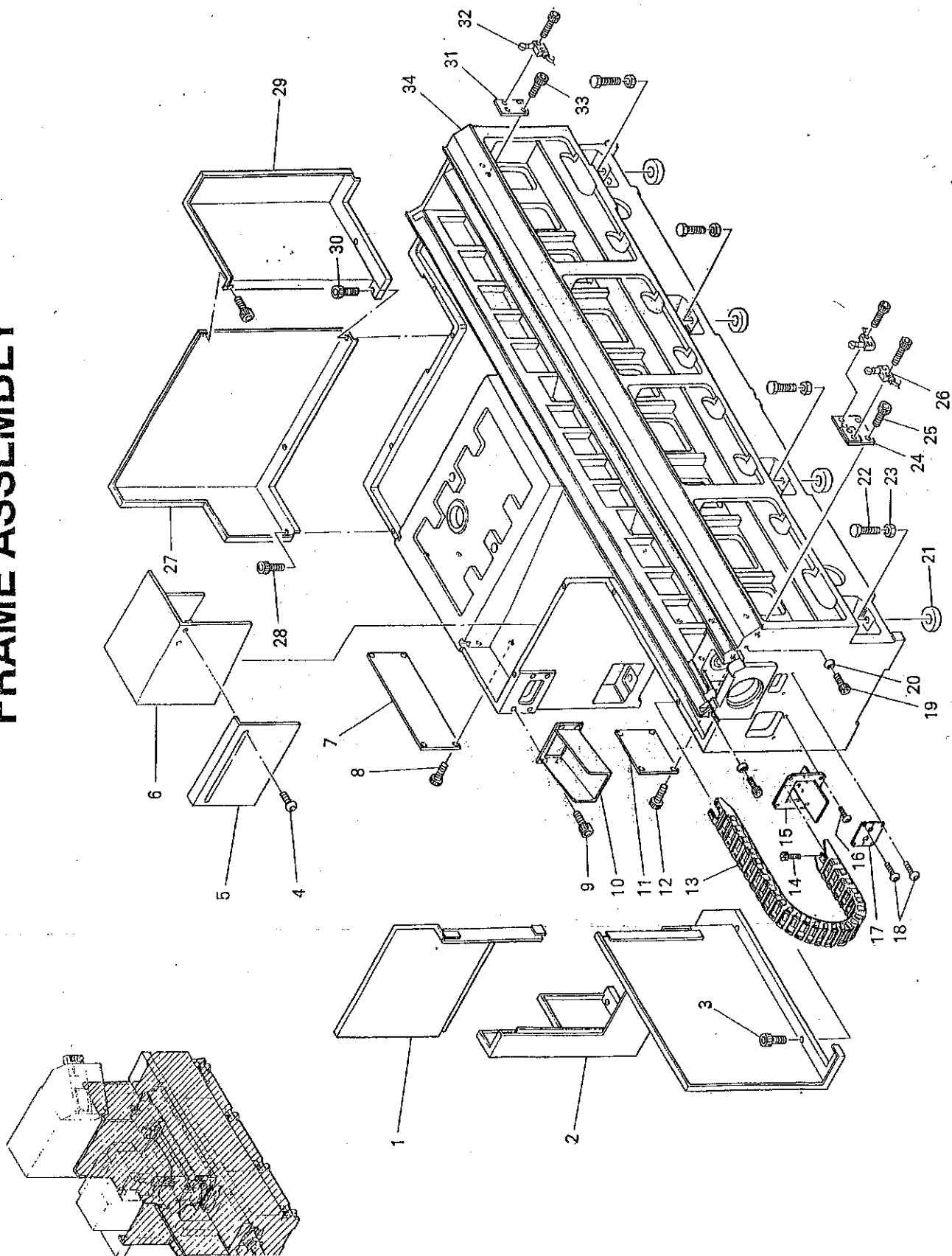

FRAME ASSEMBLY

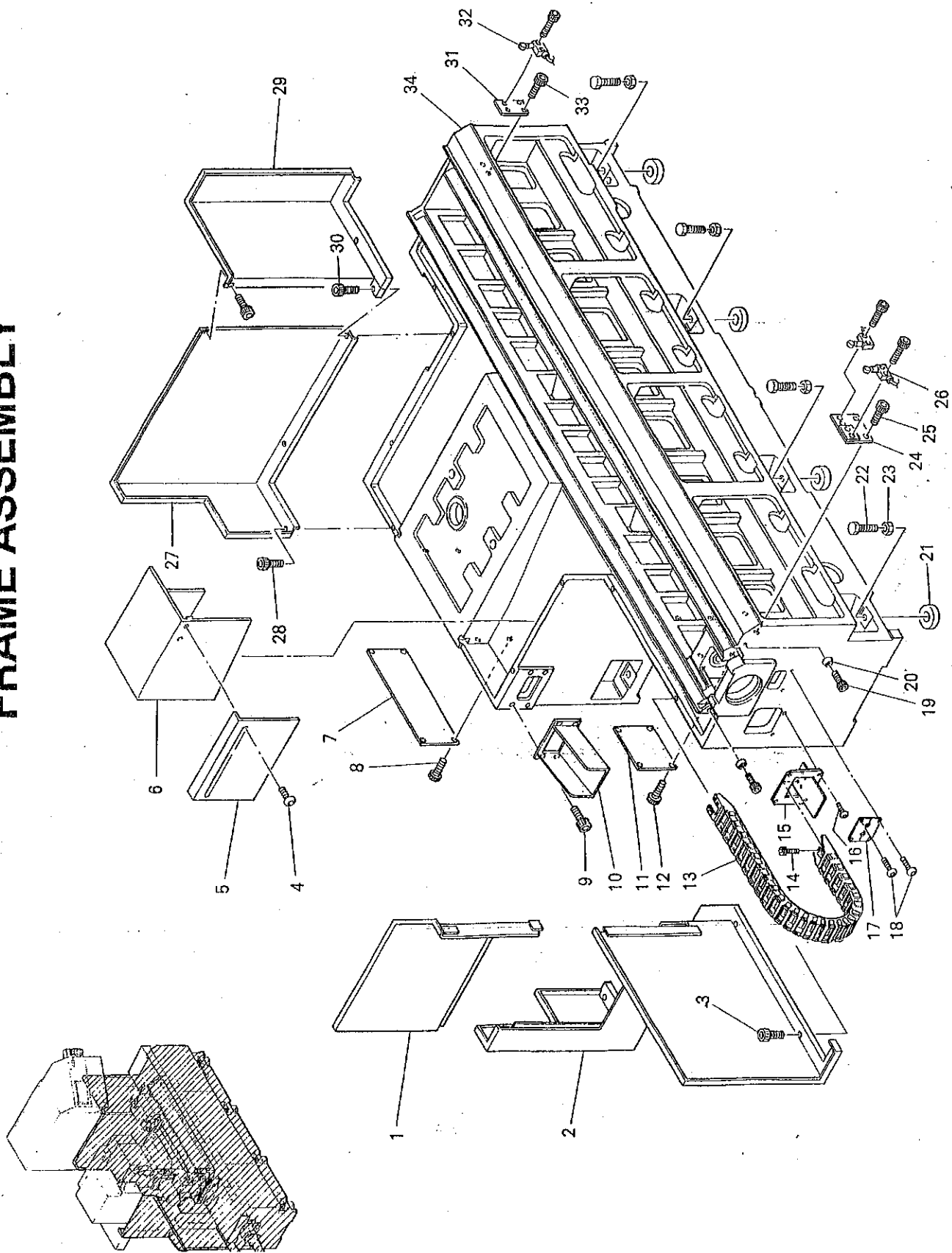

FRAME ASSEMBLY

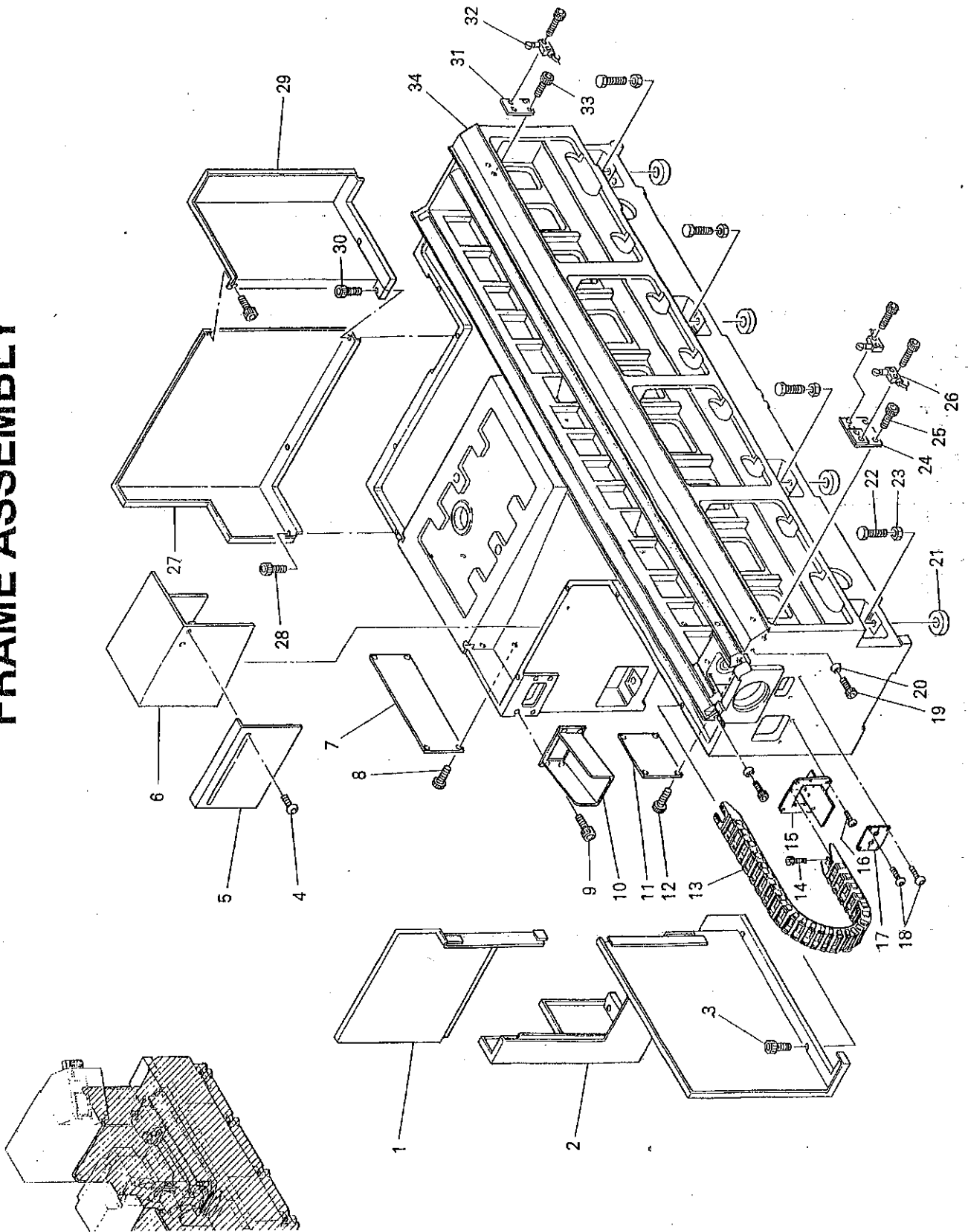

FRAME ASSEMBLY

NO.	PART CODE	PART NAME	Q'TY											
			340P 12-16P	360P 12-24P	3100P 12-40P	3160P 12-60P	340U 12-16U	360U 12-24U	3100U 12-40U	3160U 12-60U				
34	5050037G1	フレーム Frame	-	-	-	1	-	-	-	-	-	-	1	

GRINDING HEAD ASSEMBLY 1/2

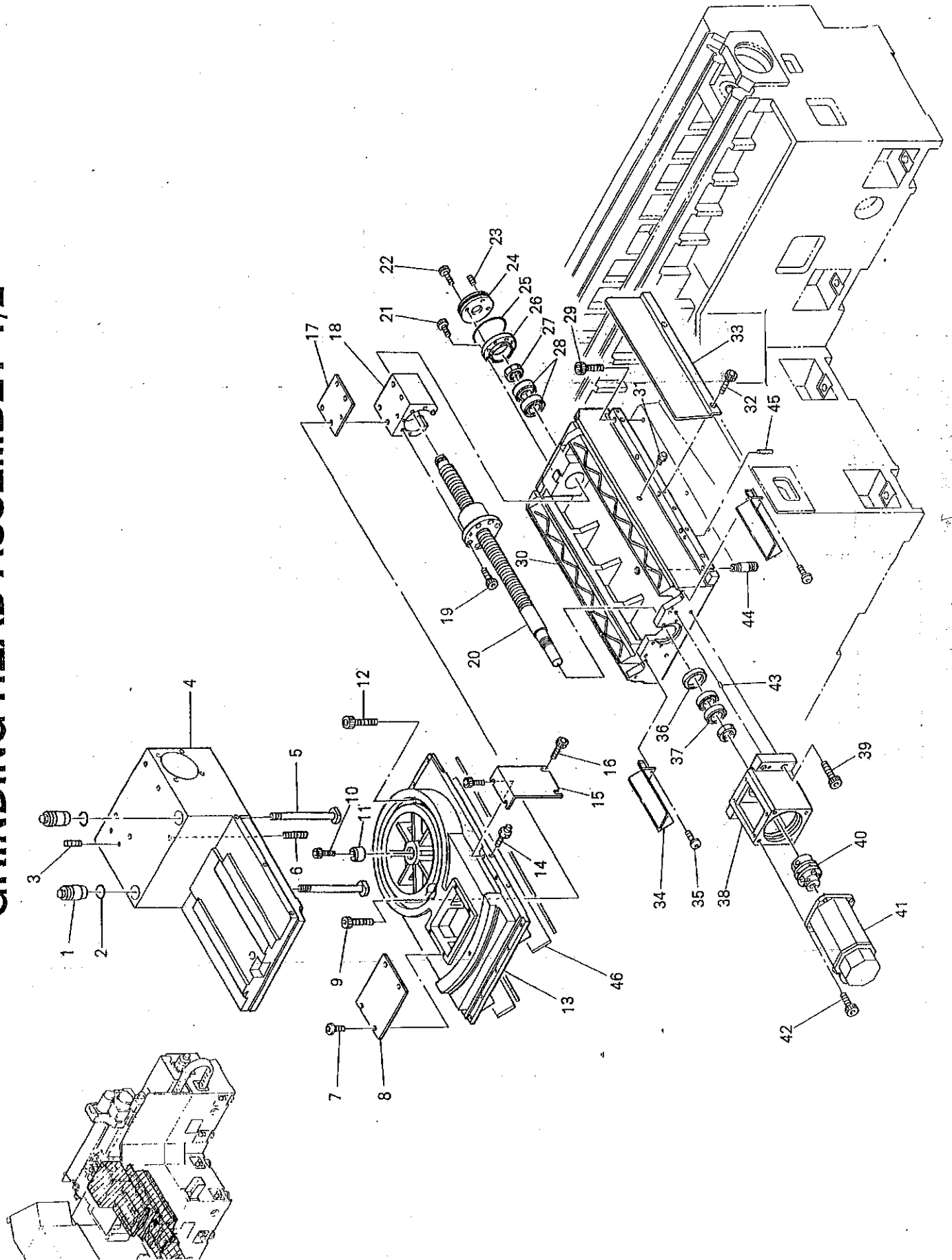

GRINDING HEAD ASSEMBLY 1/2

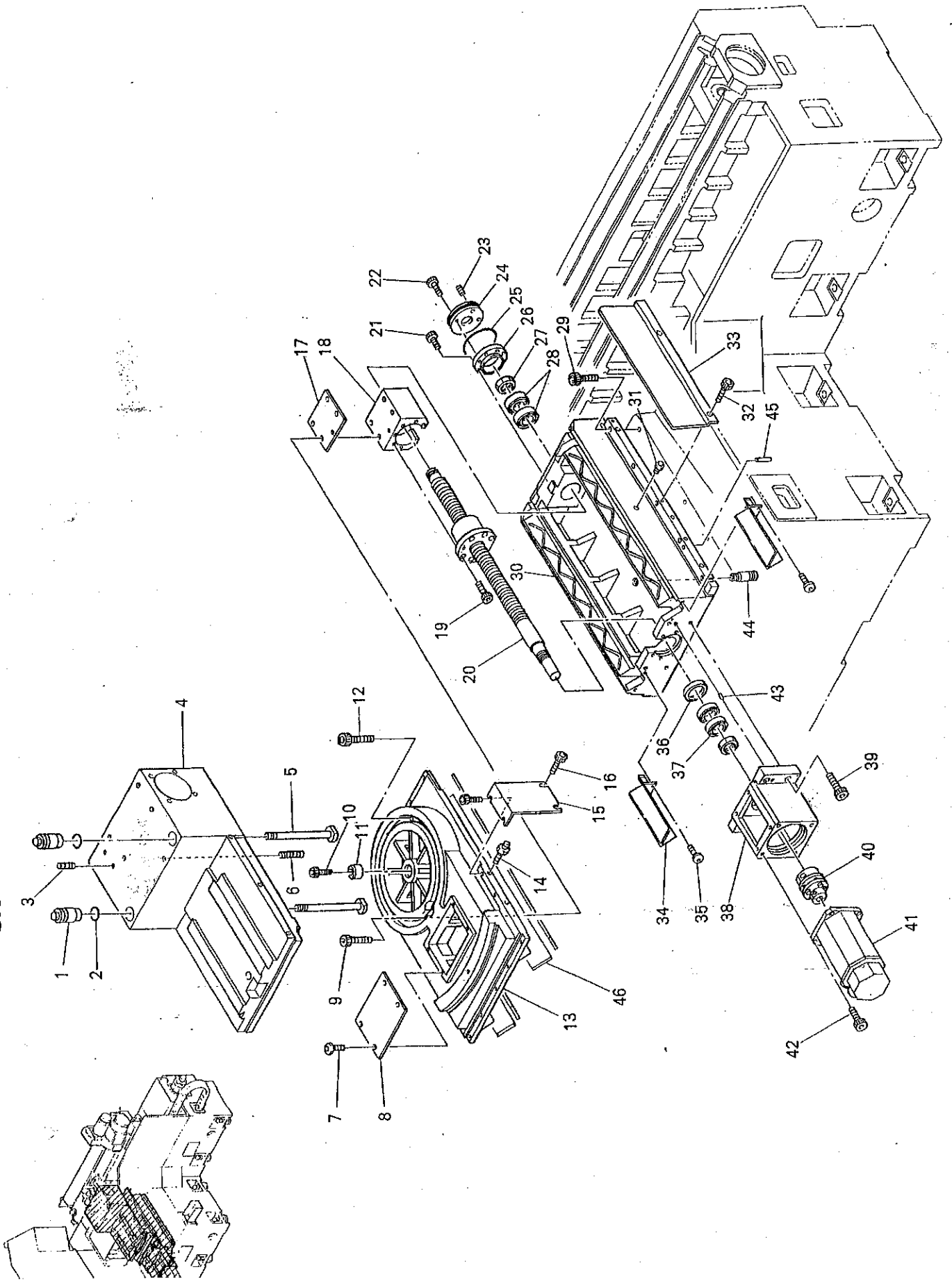

GRINDING HEAD ASSEMBLY 2/2

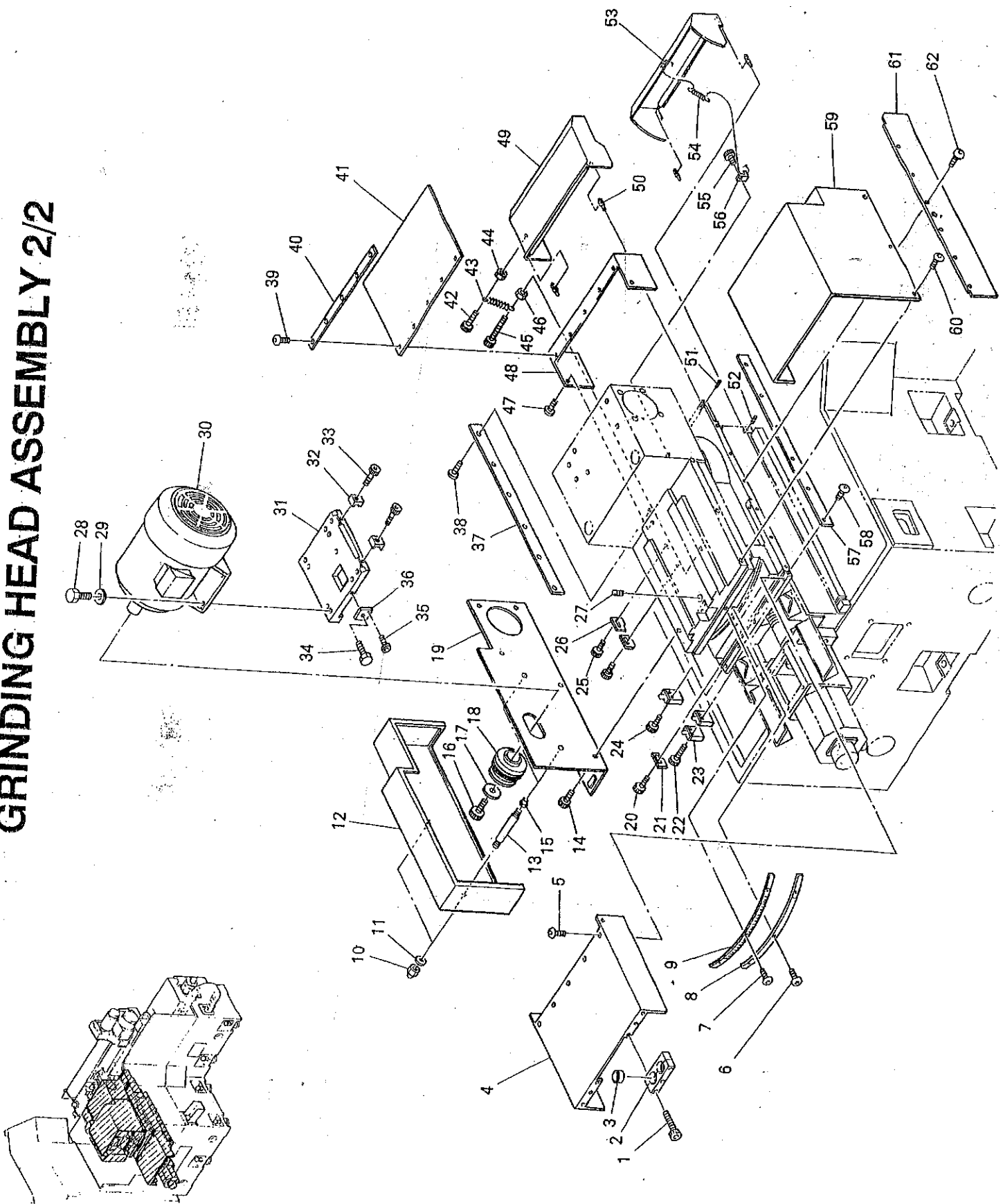

GRINDING HEAD ASSEMBLY 2/2

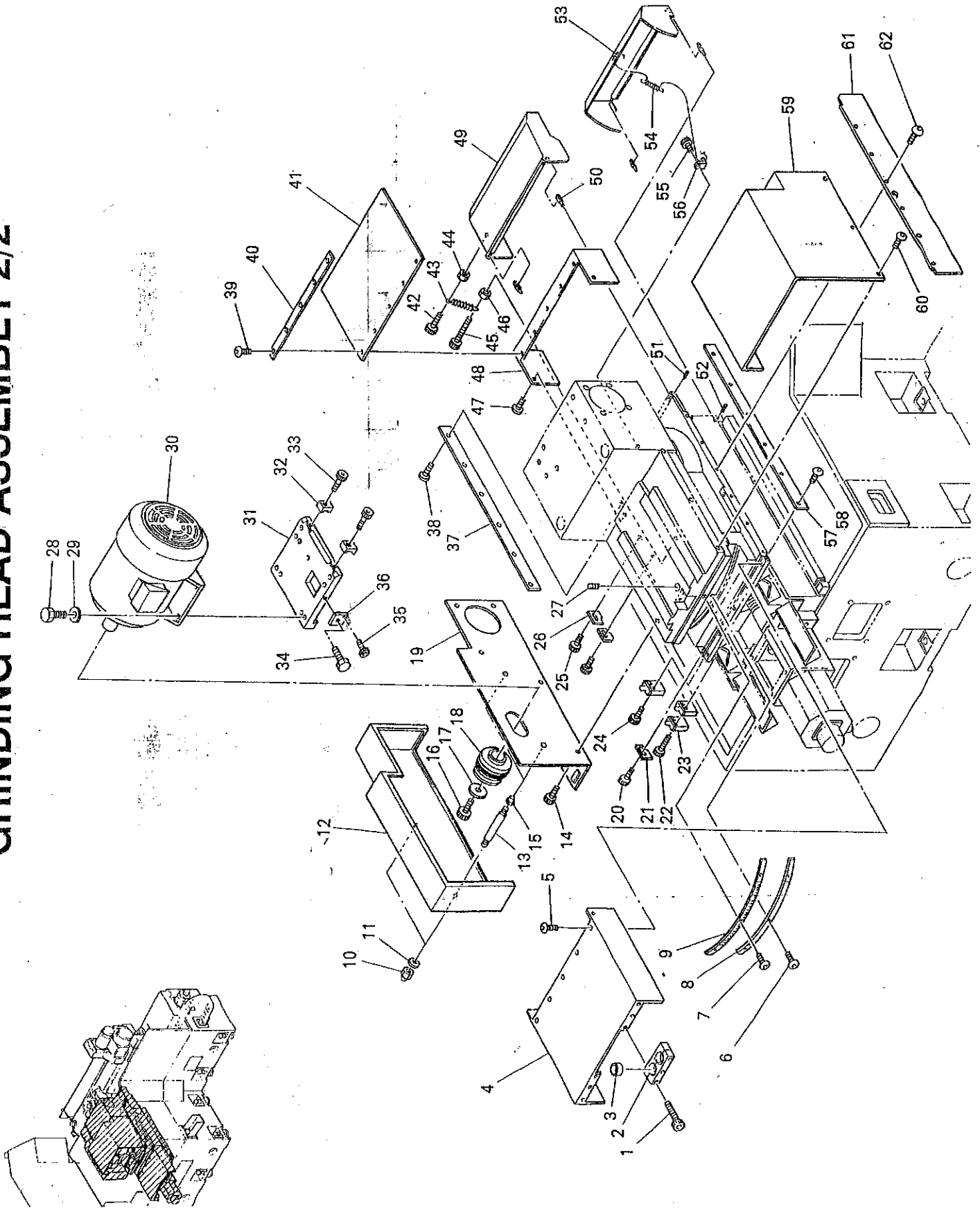

TABLE TRAVERSE ASSEMBLY

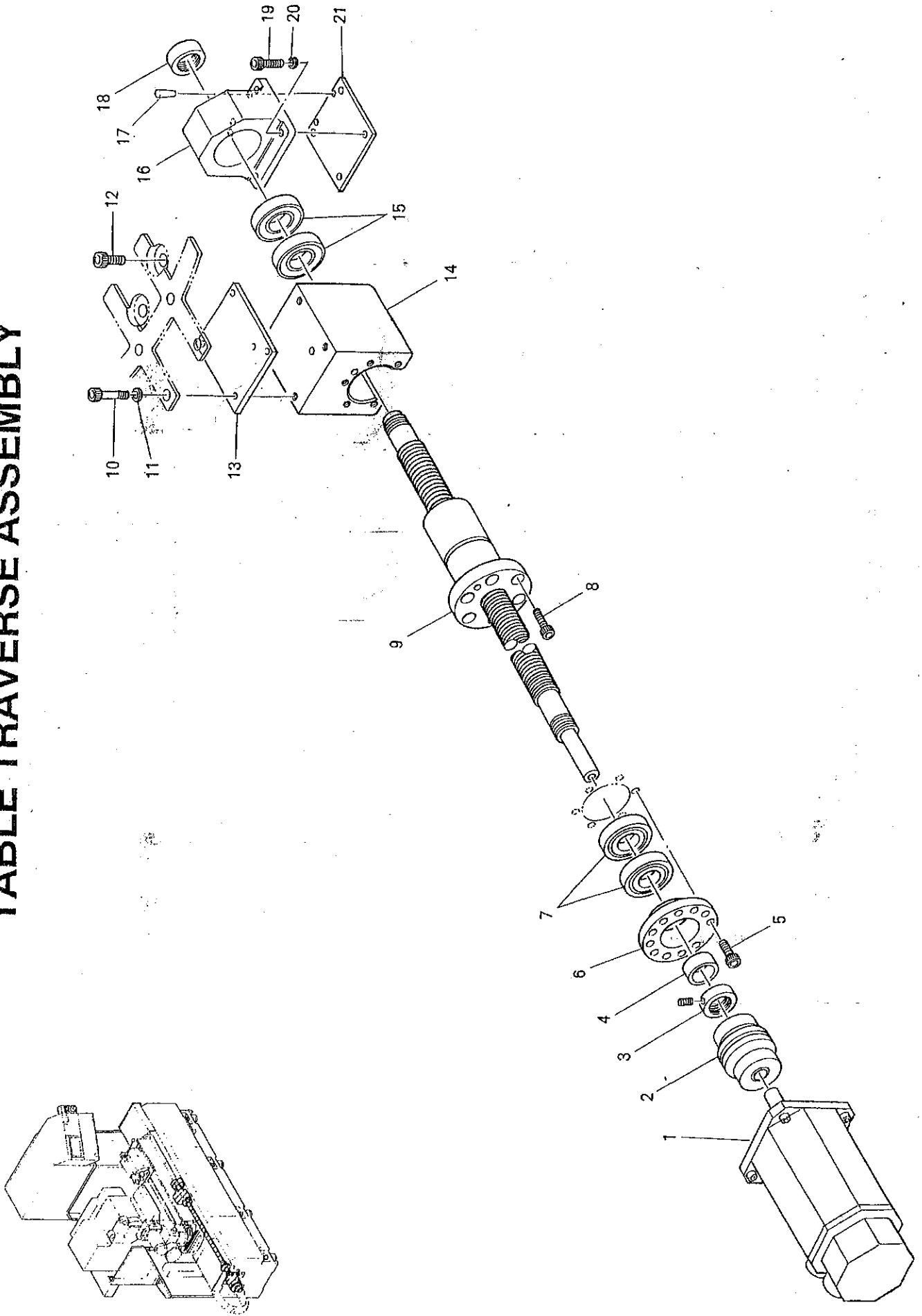
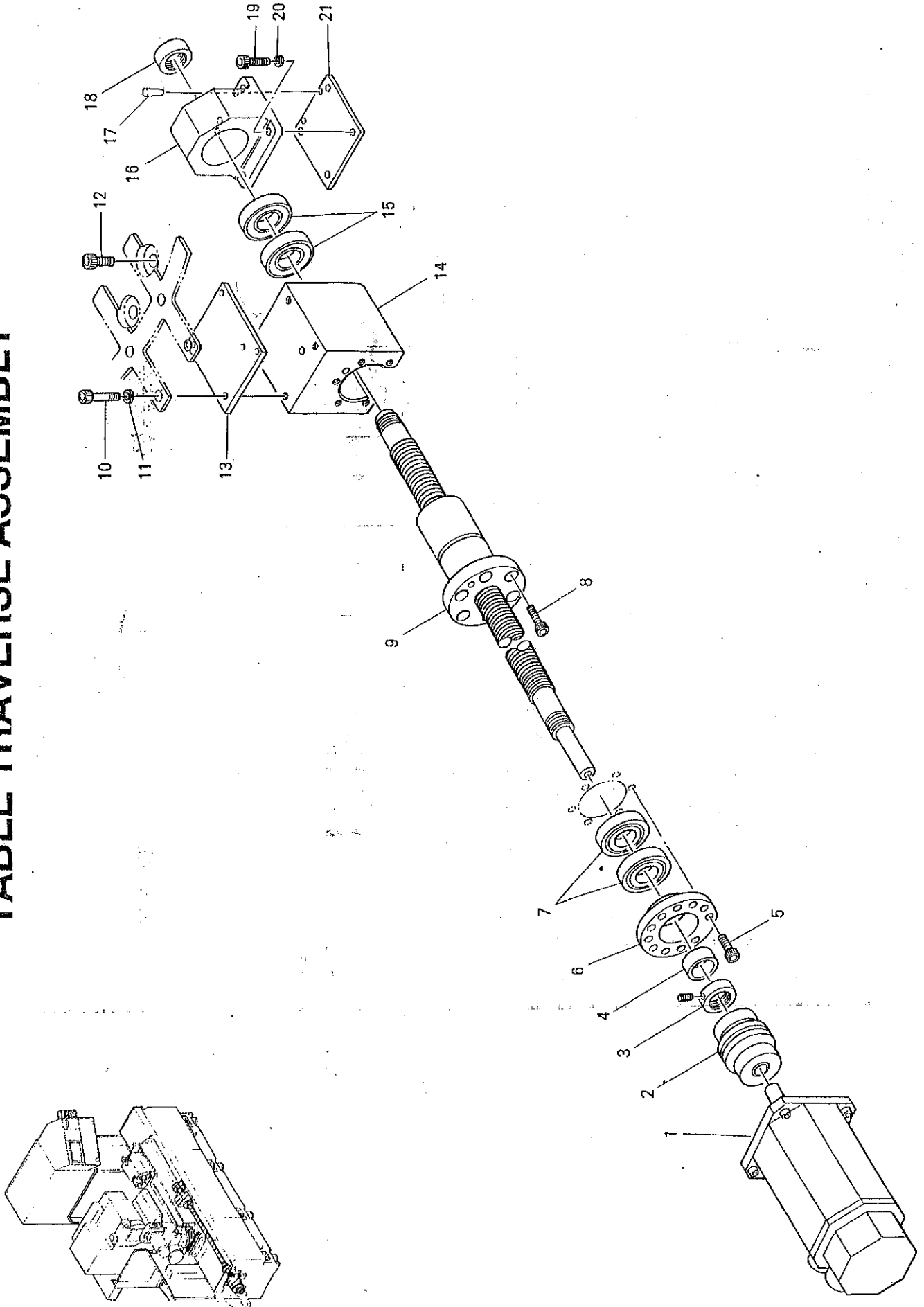
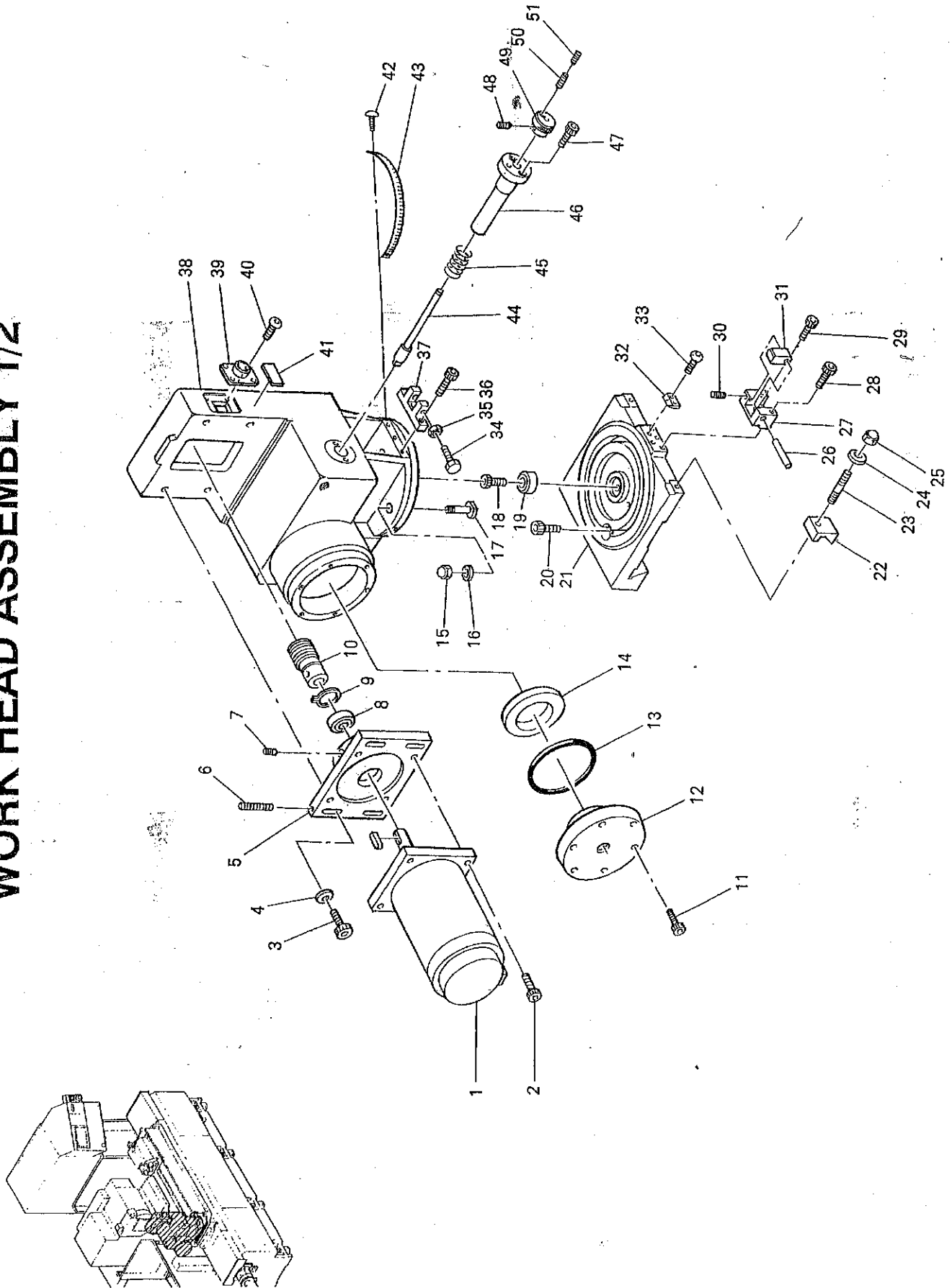

TABLE TRAVERSE ASSEMBLY



WORK HEAD ASSEMBLY 1/2



WORK HEAD ASSEMBLY 1/2

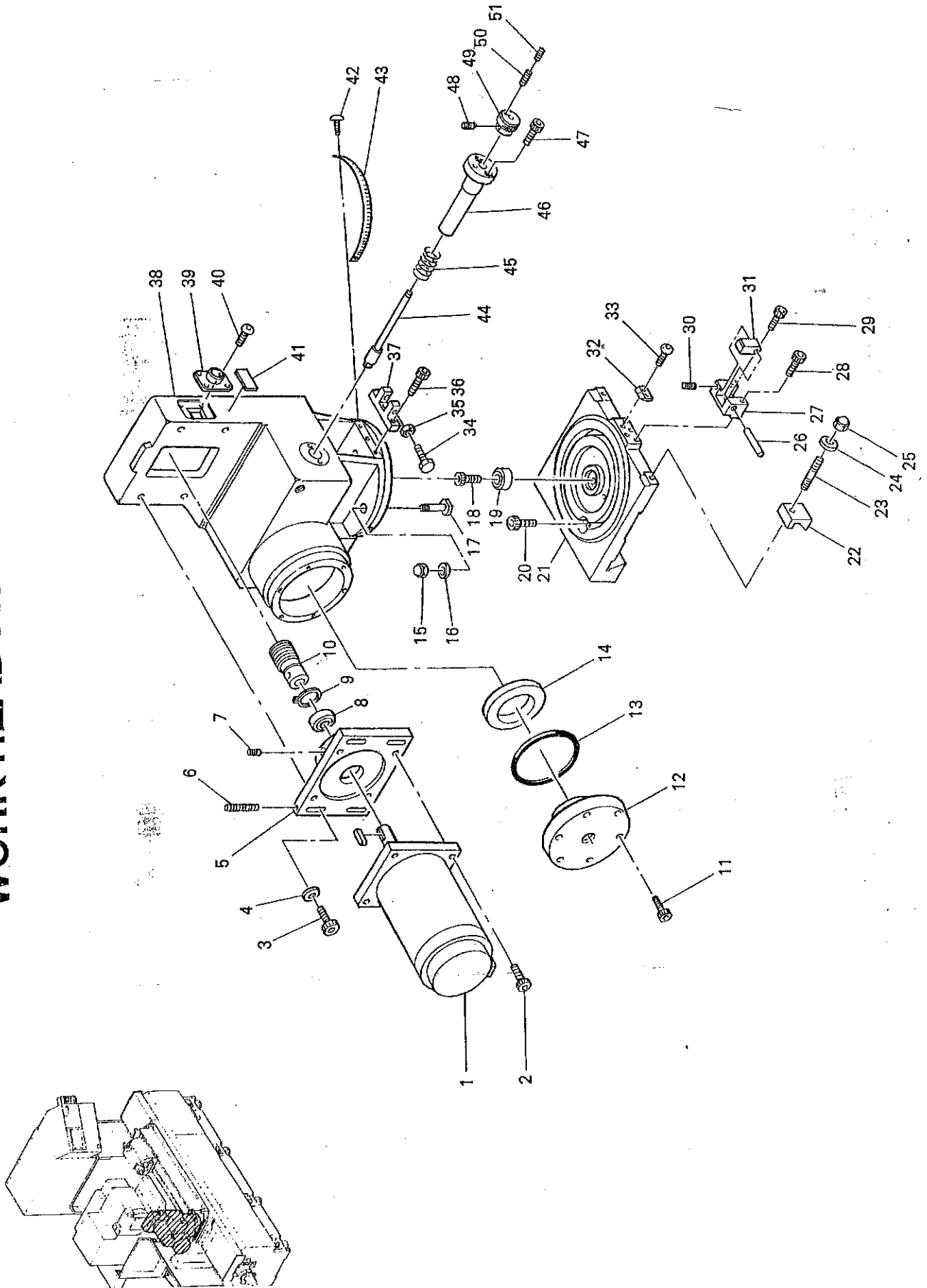

WORK HEAD ASSEMBLY 2/2

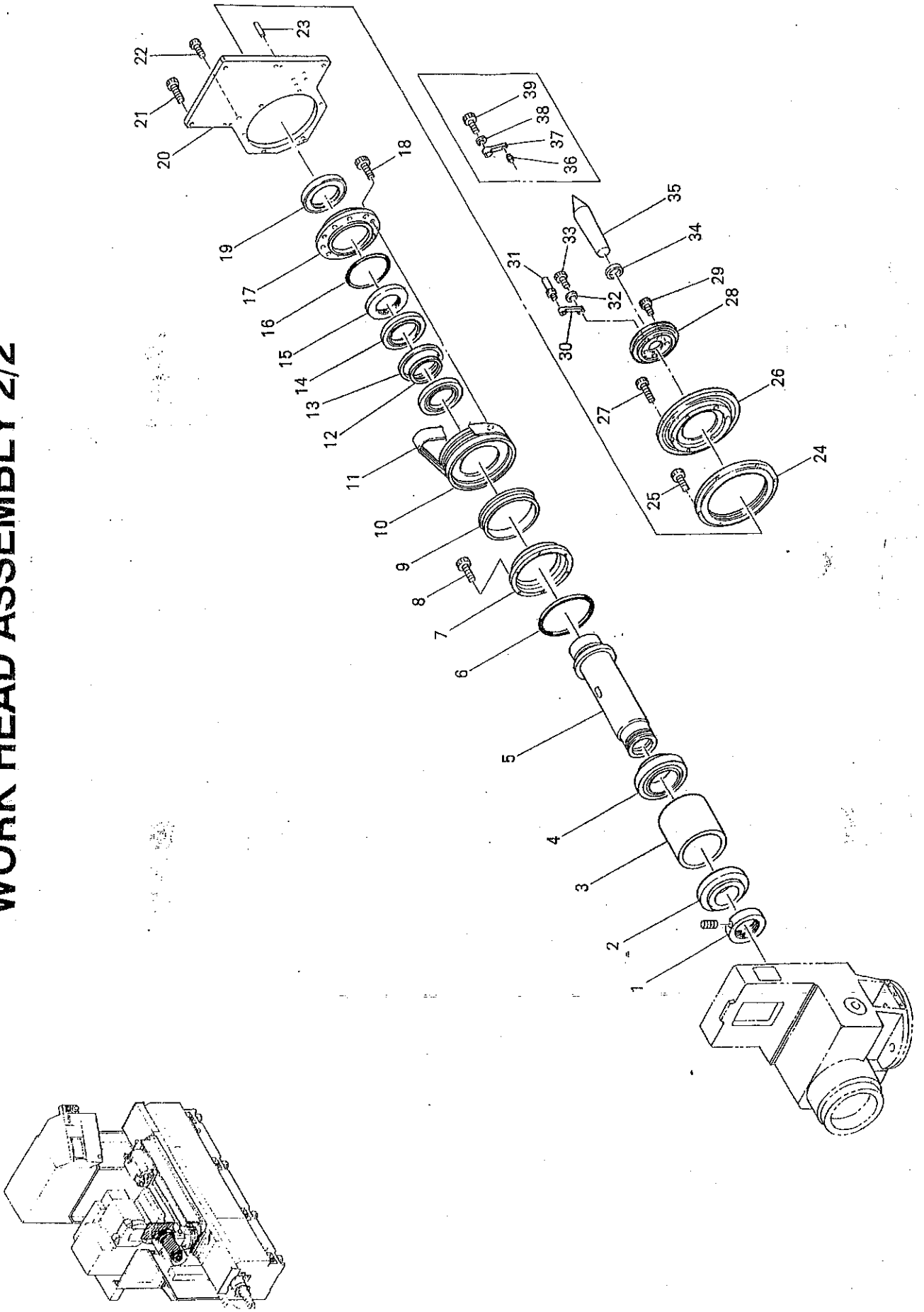

WORK HEAD ASSEMBLY 2/2

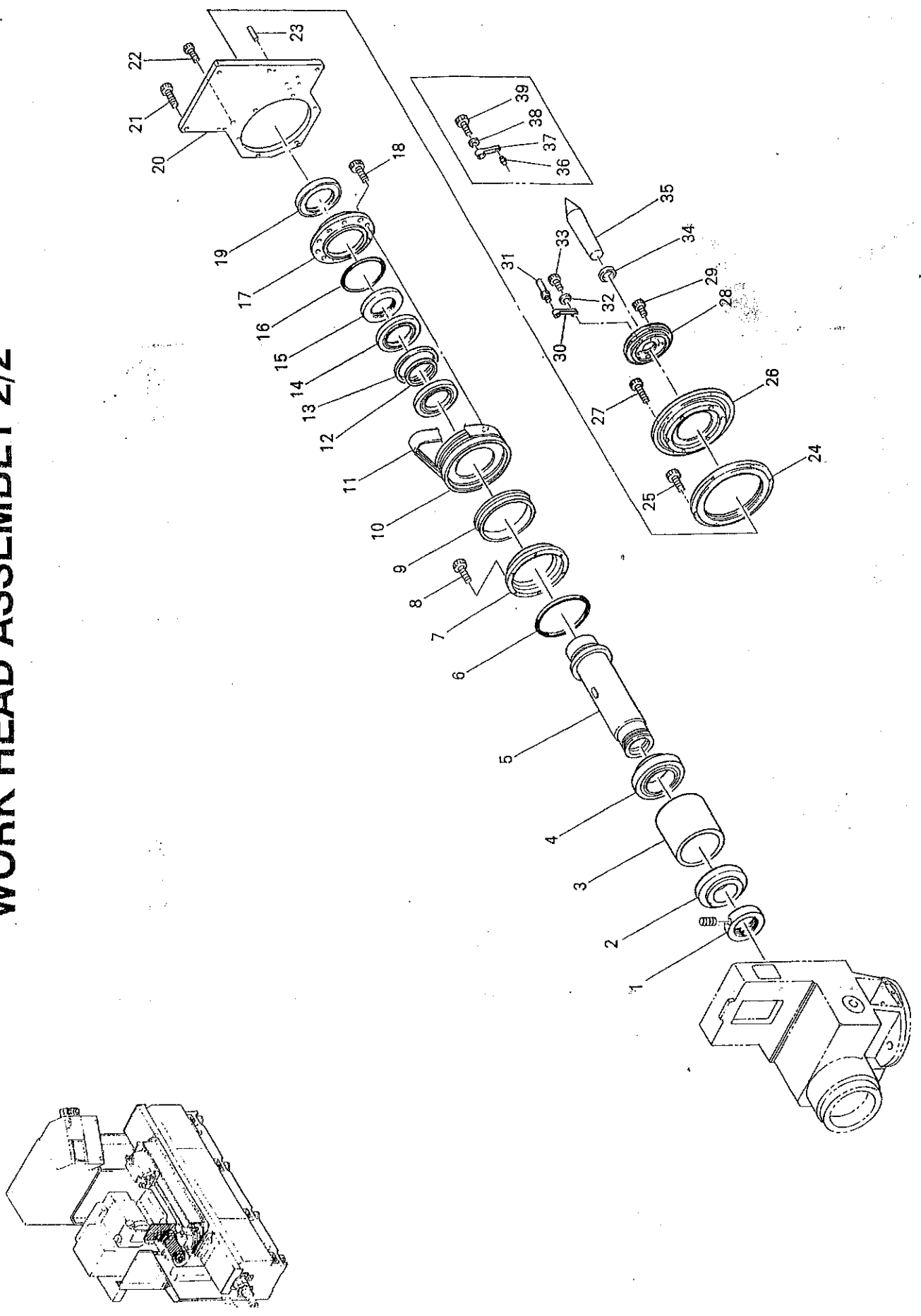

WHEEL GUARD ASSEMBLY (ϕ 355, ϕ 305, ϕ 405)

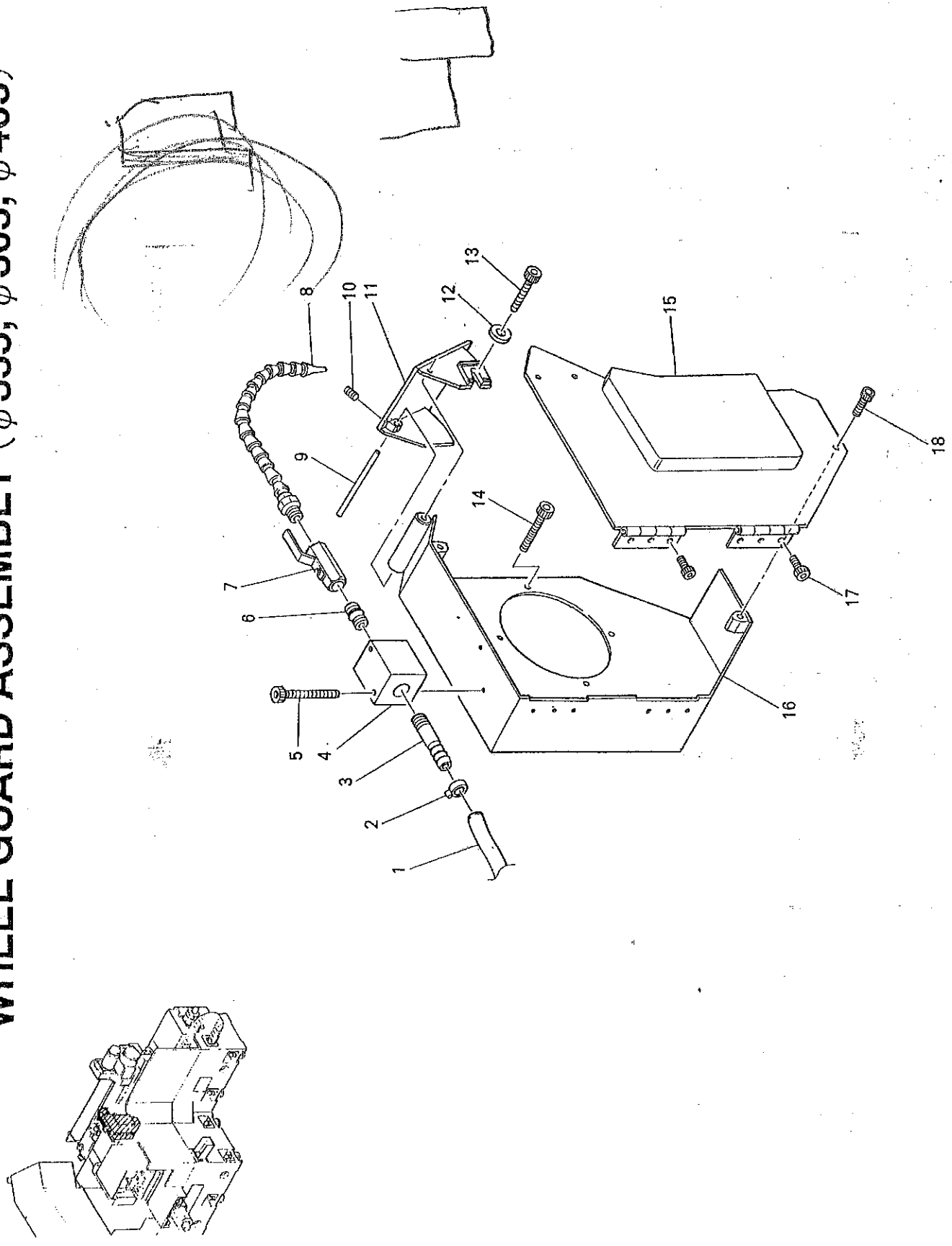

WHEEL GUARD ASSEMBLY (ϕ 355, ϕ 305, ϕ 405)

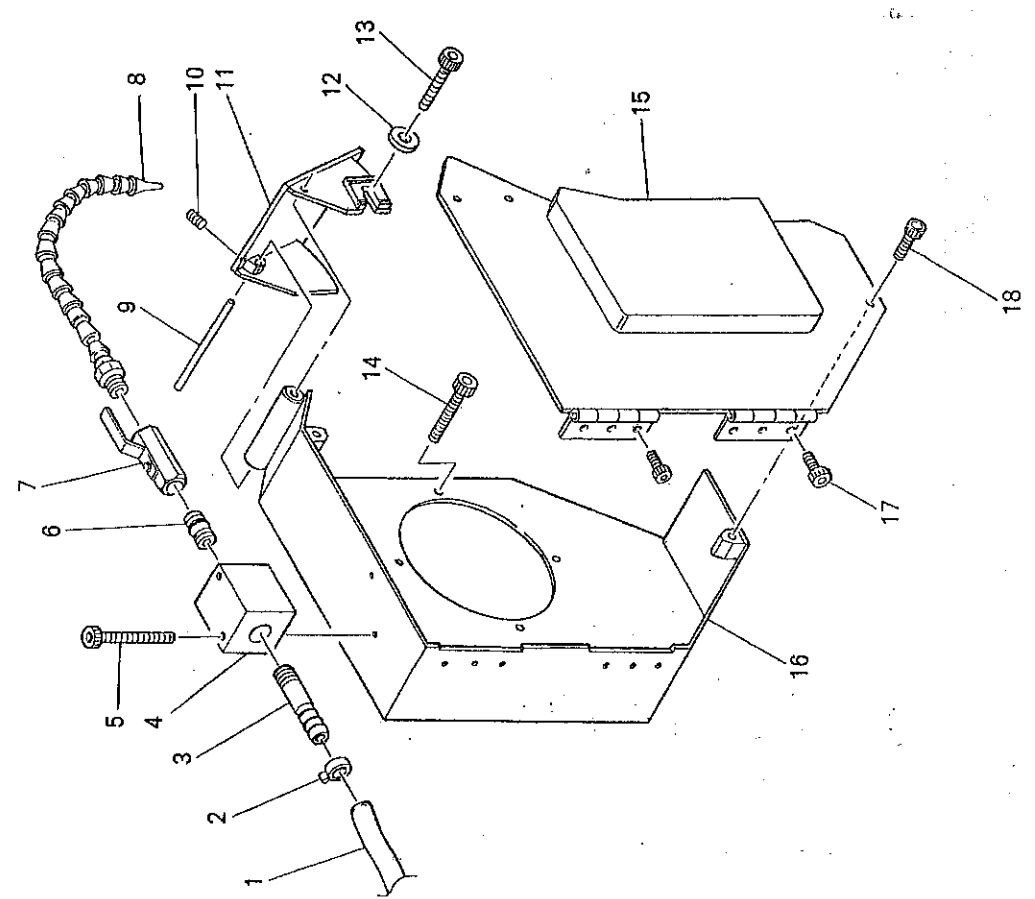
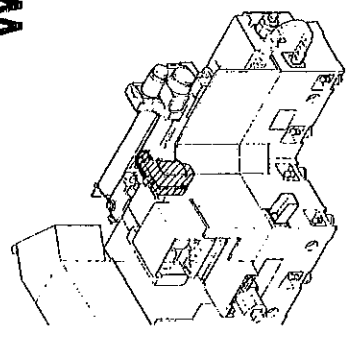

SPINDLE ASSEMBLY

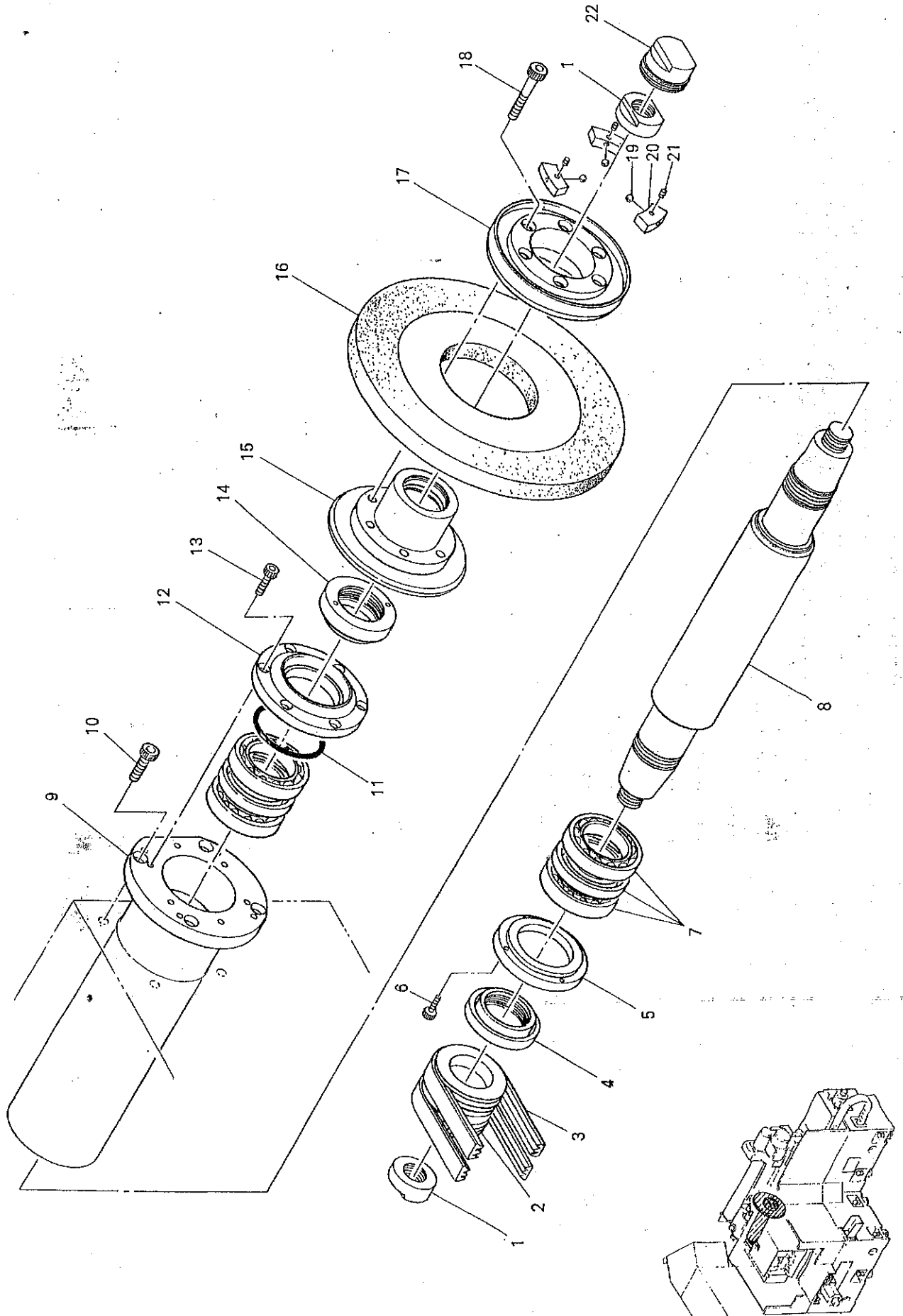

TAIL STOCK ASSEMBLY

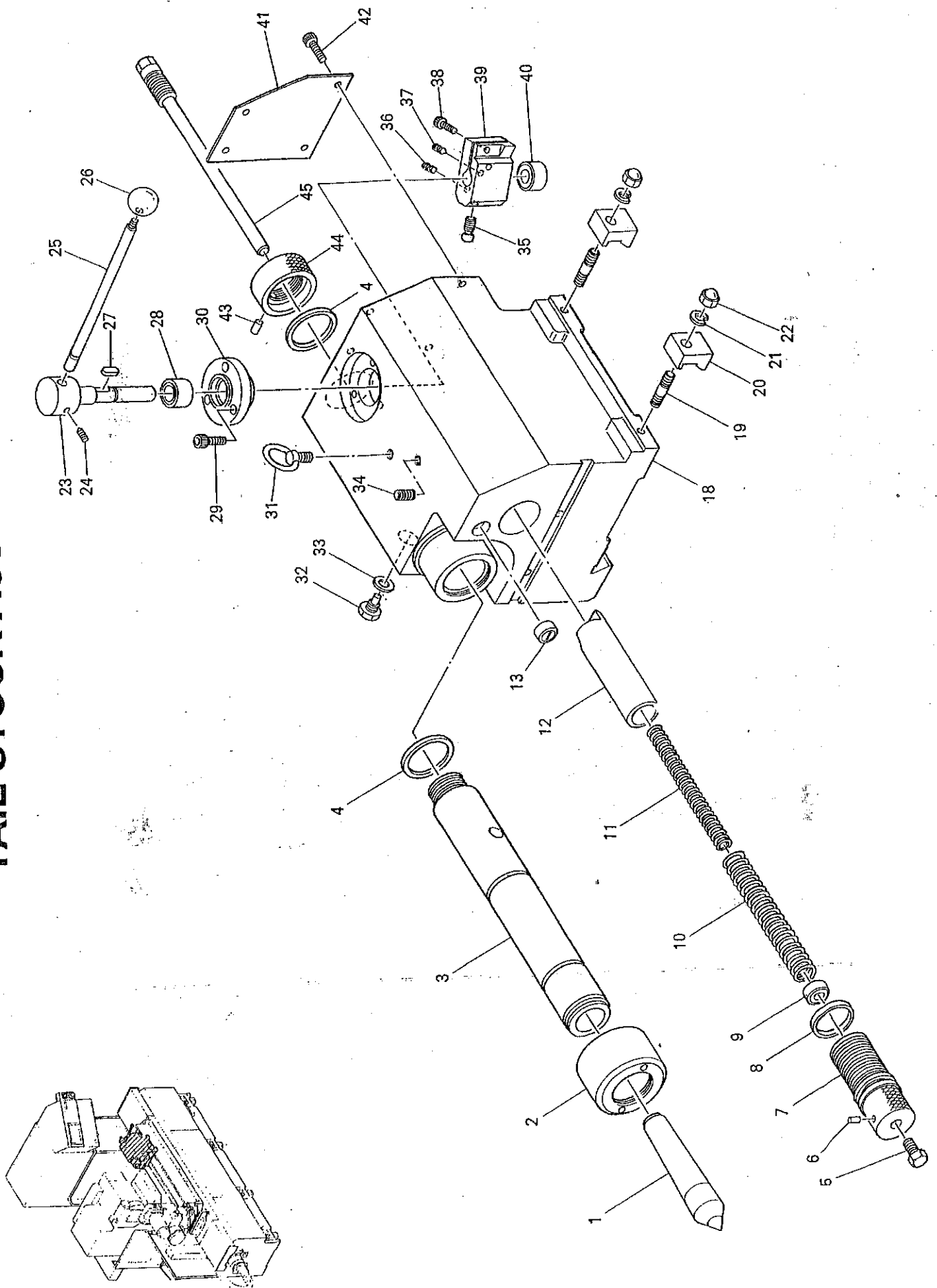

TAIL STOCK ASSEMBLY

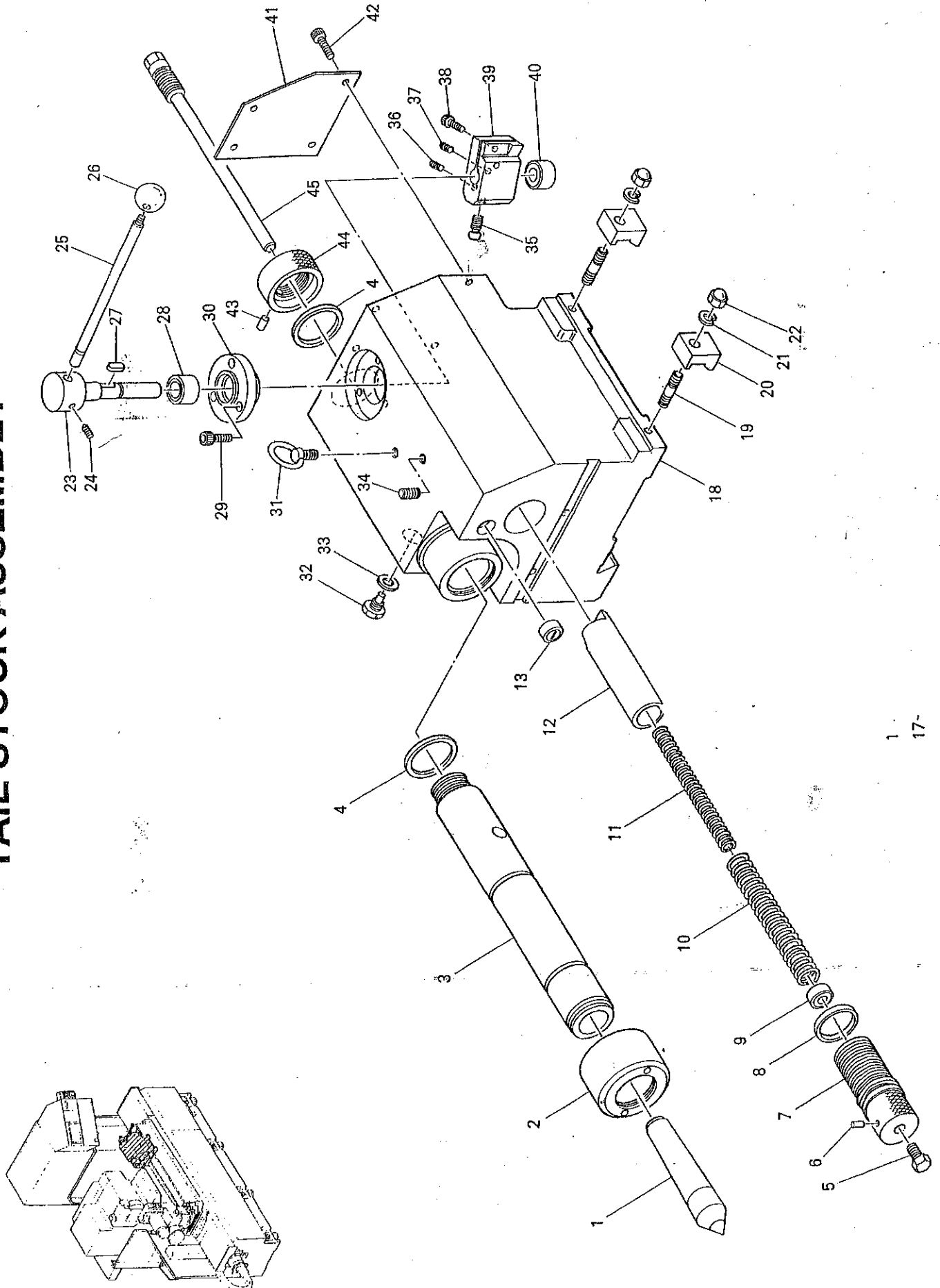

TABLE ASSEMBLY 1/2

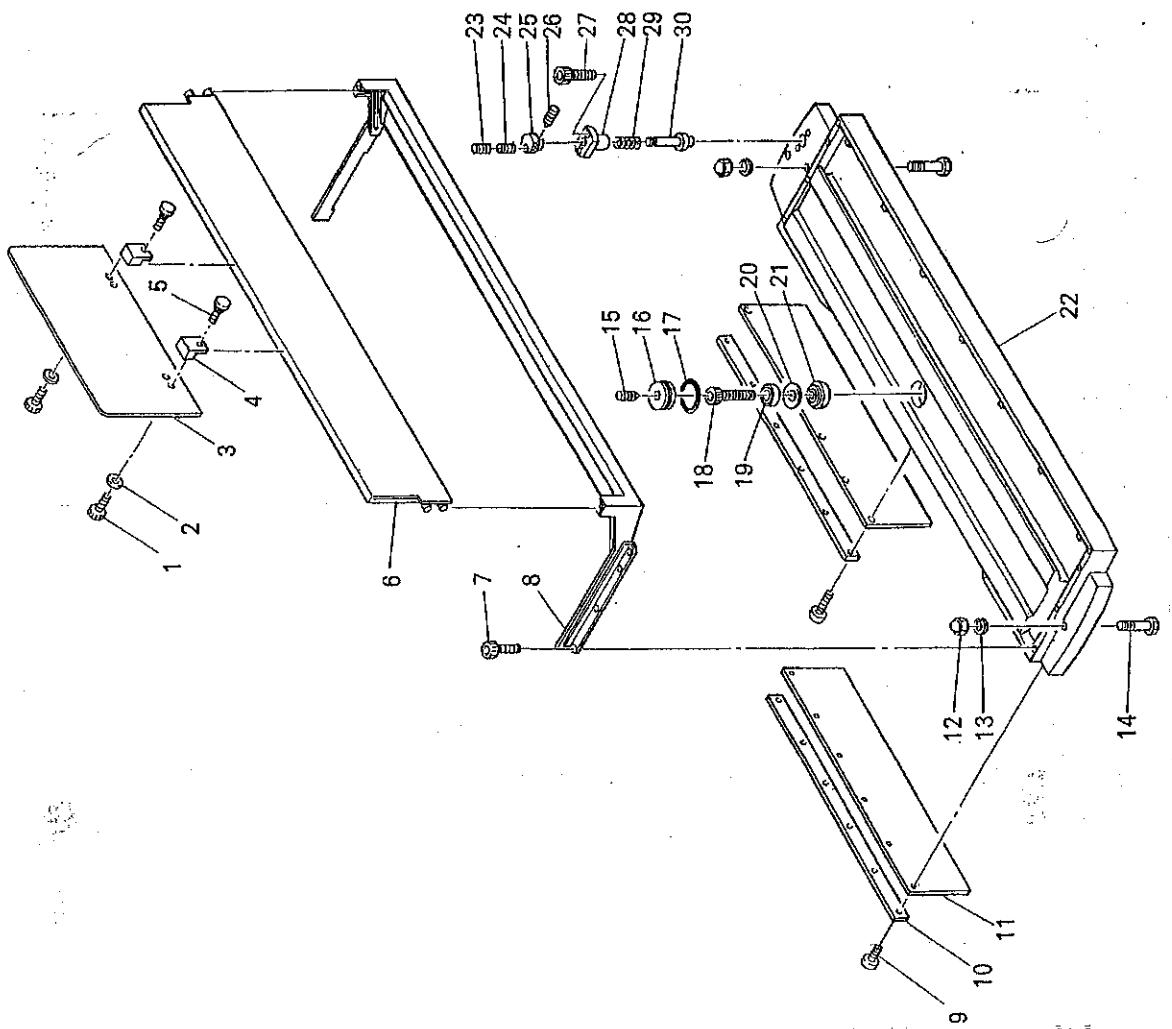
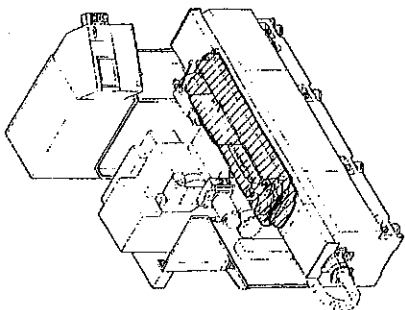

TABLE ASSEMBLY 1/2

NO.	PART CODE	PART NAME	Q'TY															
			340P		360P		3100P		3160P		340U		360U		3100U		3160U	
			12-16P	12-24P	12-24P	12-40P	12-40P	12-60P	12-16U	12-24U	12-24U	12-40U	12-40U	12-60U	12-60U			
1	5050146-01	HS 6 x 15	4	4	-	-	4	-	-	-	-	4	4	-	-	-	-	
	5051009-01	HS 6 x 15	-	-	4	-	-	-	-	-	-	-	-	4	-	-	-	
	5051010-01	HS 6 x 15	-	-	-	-	-	-	-	4	-	-	-	-	-	-	4	
2	5050146-01	WS 6	4	4	-	-	-	-	-	-	-	4	4	-	-	-	-	
	5051009-01	WS 6	-	-	4	-	-	-	-	-	-	-	-	4	-	-	-	
	5051010-01	WS 6	-	-	-	-	-	-	-	4	-	-	-	-	-	-	4	
3	5050146A3	カバー	1	1	-	-	-	-	-	-	-	1	1	-	-	-	-	
	5051009A3	カバー	-	-	1	-	-	-	-	-	-	-	-	-	1	-	-	
	5051010A3	カバー	-	-	-	-	-	-	-	1	-	-	-	-	-	-	1	
4	5050145A4	ブロック	2	2	2	2	2	2	2	2	2	2	2	2	2	2	2	
5	5050145-01	ナールドノブ KS20 x 10	2	2	2	2	2	2	2	2	2	2	2	2	2	2	2	
6	5051027A2	カバー-A	1	-	-	-	-	-	-	-	-	1	-	-	-	-	-	
	5050139B2	カバー-A	-	1	-	-	-	-	-	-	-	-	1	-	-	-	-	
	5050159A2	カバー-A	-	-	-	1	-	-	-	-	-	-	-	1	-	-	-	
	5050160A2	カバー-A	-	-	-	-	-	-	-	1	-	-	-	-	-	-	1	
7	5051026-01	HS ボタン 6 x 10	8	-	-	-	-	-	-	-	-	8	-	-	-	-	-	
	5050137-01	HS ボタン 6 x 10	-	8	-	-	-	-	-	-	-	-	8	-	-	-	-	
	5050157-01	HS ボタン 6 x 10	-	-	8	-	-	-	-	-	-	-	-	8	-	-	-	
	5050158-01	HS ボタン 6 x 10	-	-	-	-	-	-	-	8	-	-	-	-	-	-	8	
8	5051026A2	カバー-B	1	-	-	-	-	-	-	-	-	1	-	-	-	-	-	
	5050137C2	カバー-B	-	1	-	-	-	-	-	-	-	-	1	-	-	-	-	
	5050157C2	カバー-B	-	-	1	-	-	-	-	-	-	-	-	1	-	-	-	
	5050158C2	カバー-B	-	-	-	-	-	-	-	1	-	-	-	-	-	-	1	
9	5051367-01	HS ボタン 5 x 10	10	-	-	-	-	-	-	-	-	10	-	-	-	-	-	
	5050110-01	HS ボタン 5 x 10	-	12	-	-	-	-	-	-	-	-	12	-	-	-	-	
	5050988-01	HS ボタン 5 x 10	-	-	22	-	-	-	-	-	-	-	-	22	-	-	-	
	5050988-01	HS ボタン 5 x 10	-	-	-	-	-	-	-	28	-	-	-	-	-	-	28	
10	5051367A4	オサエ板	2	-	-	-	-	-	-	-	-	2	-	-	-	-	-	
	5050110B4	オサエ板	-	2	-	-	-	-	-	-	-	-	2	-	-	-	-	
	5050988B4	オサエ板	-	-	2	-	-	-	-	-	-	-	-	2	-	-	2	

TABLE ASSEMBLY 1/2

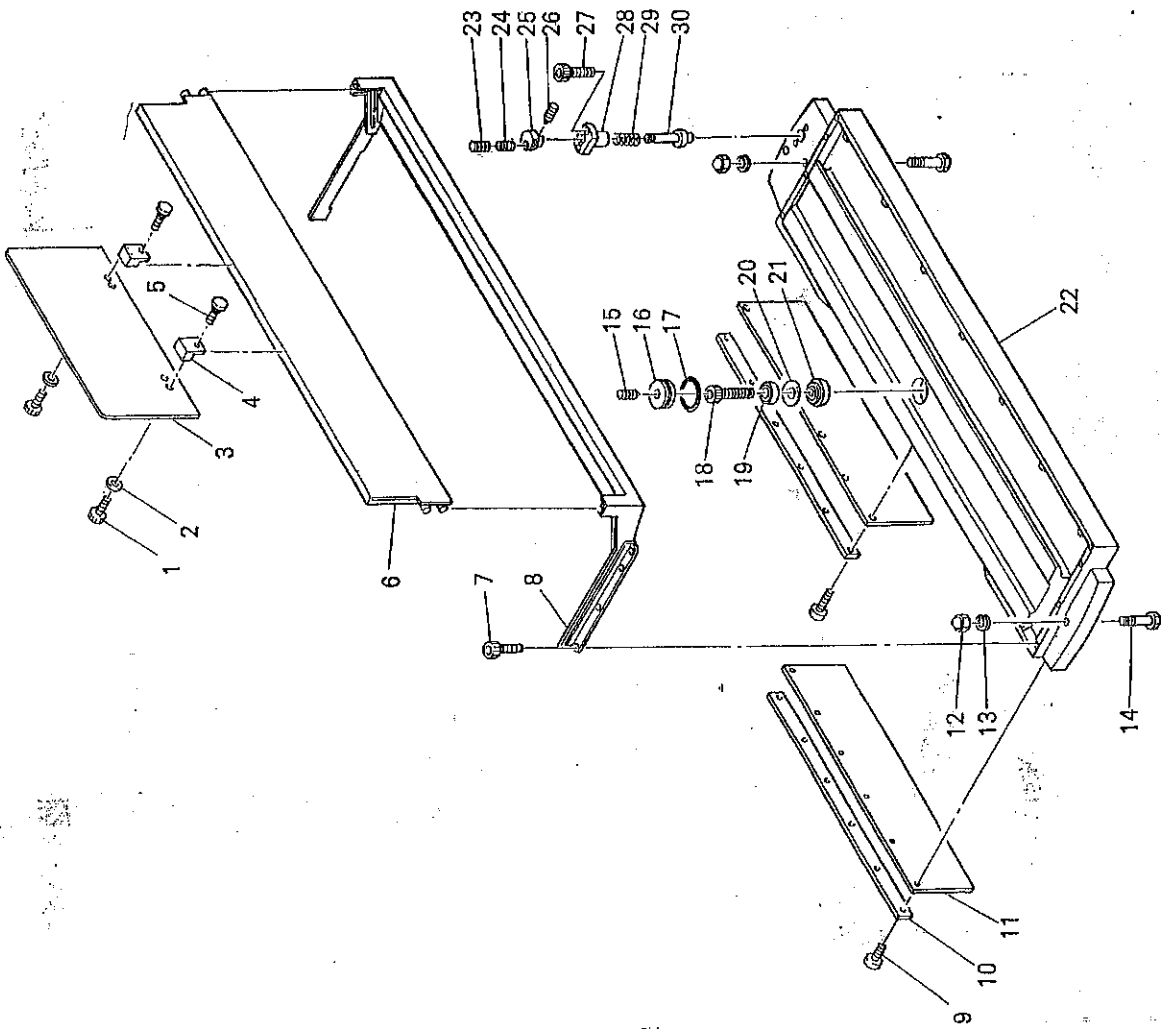
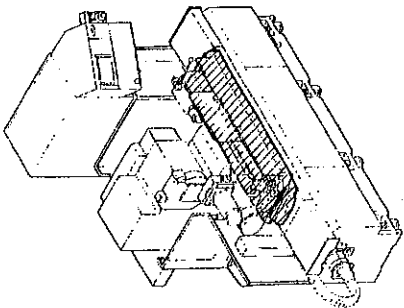

TABLE ASSEMBLY 2/2

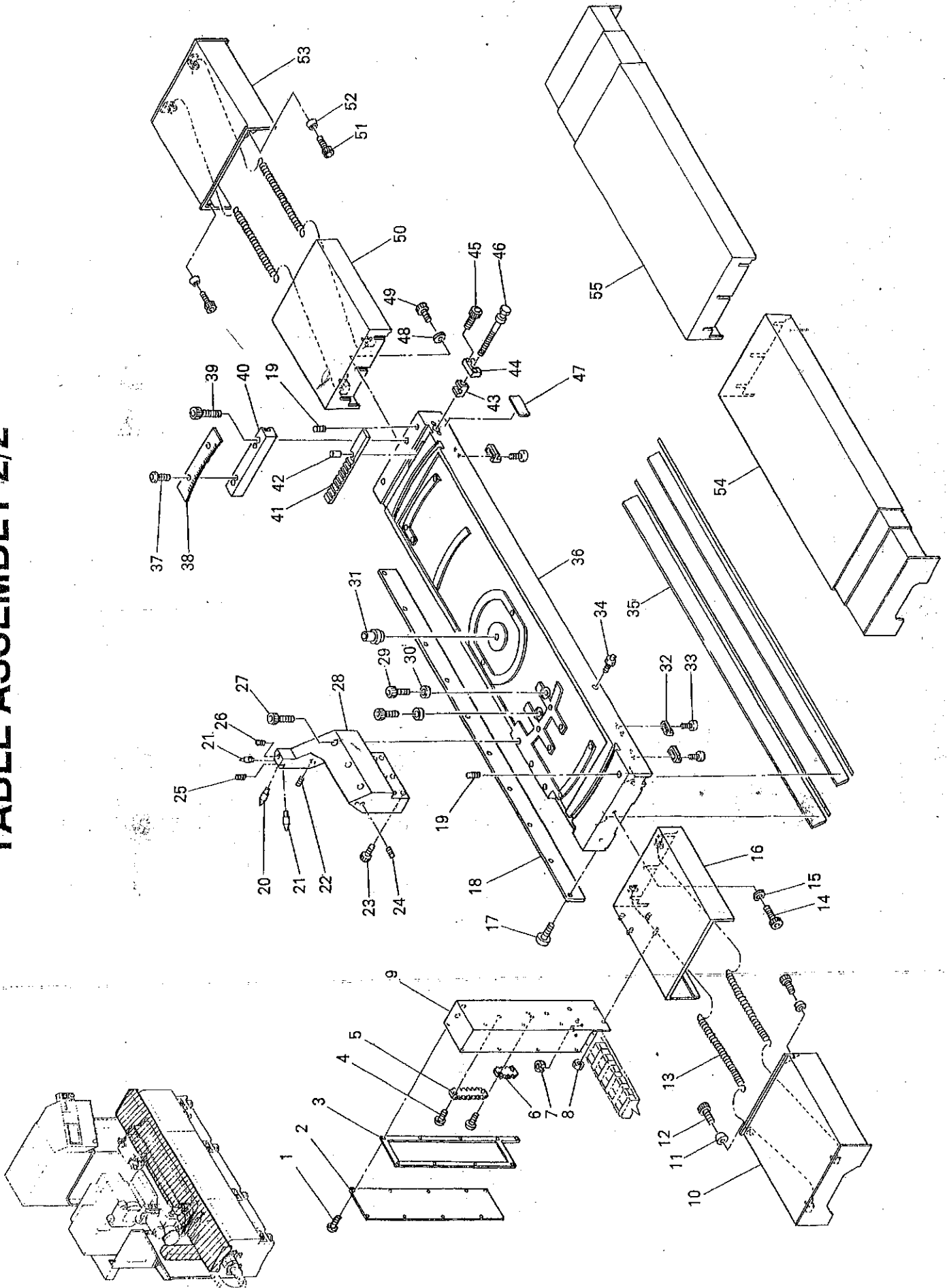

TABLE ASSEMBLY 2/2

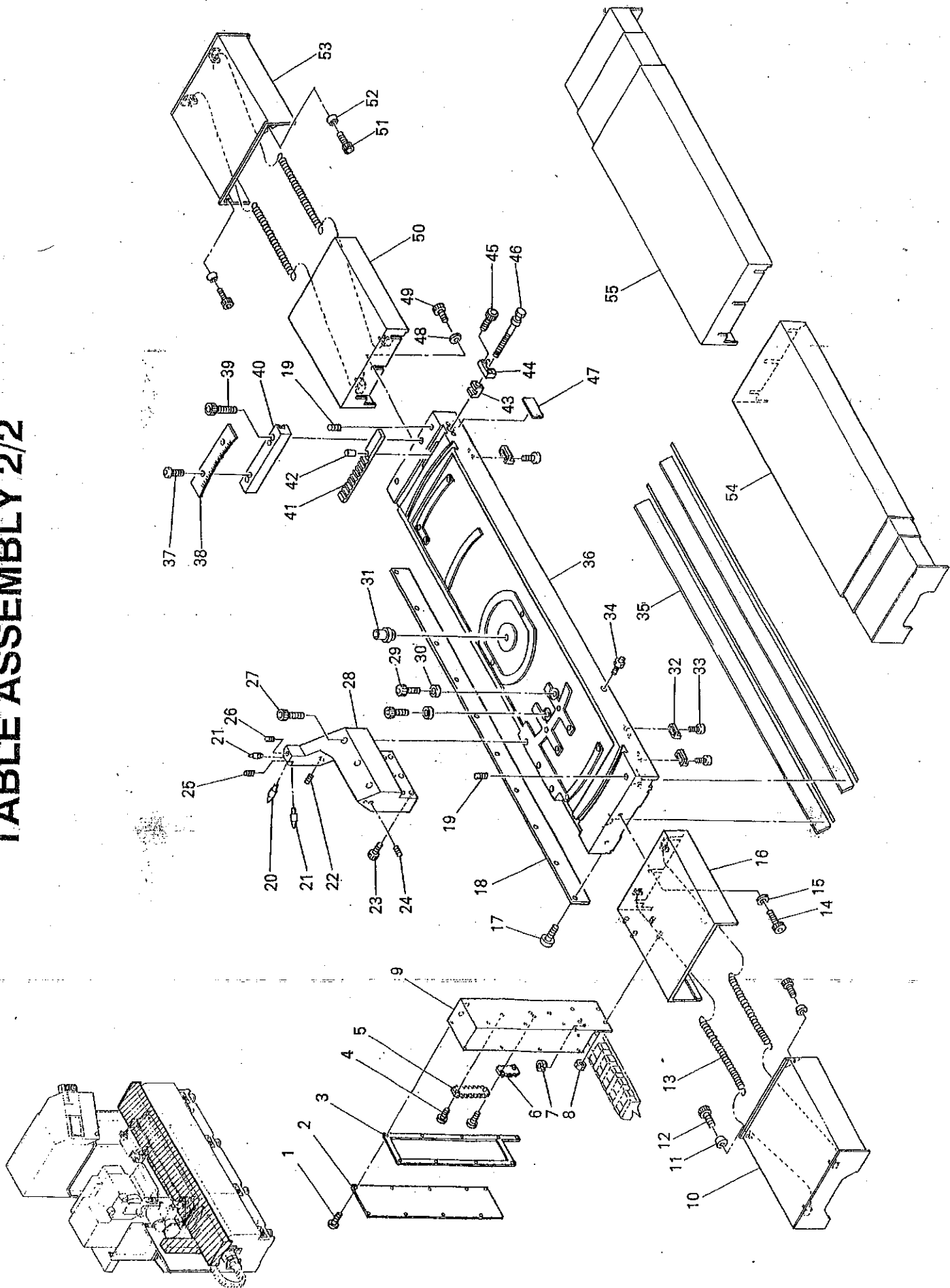

TABLE ASSEMBLY 1/2

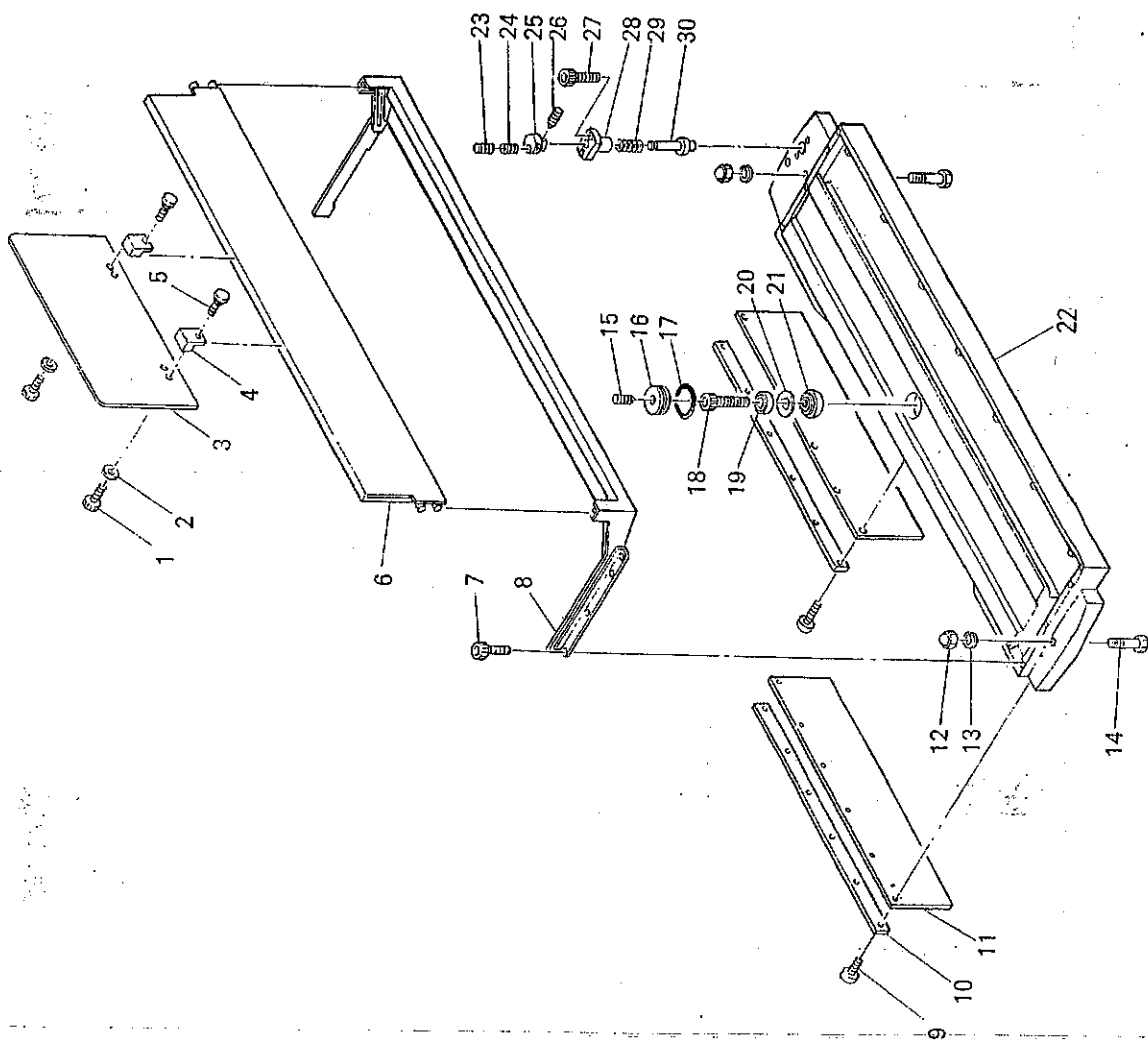
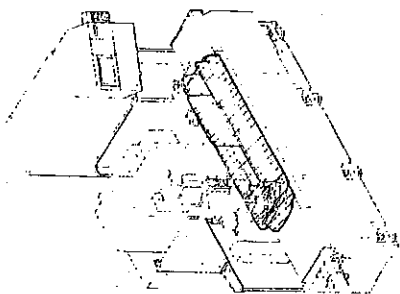
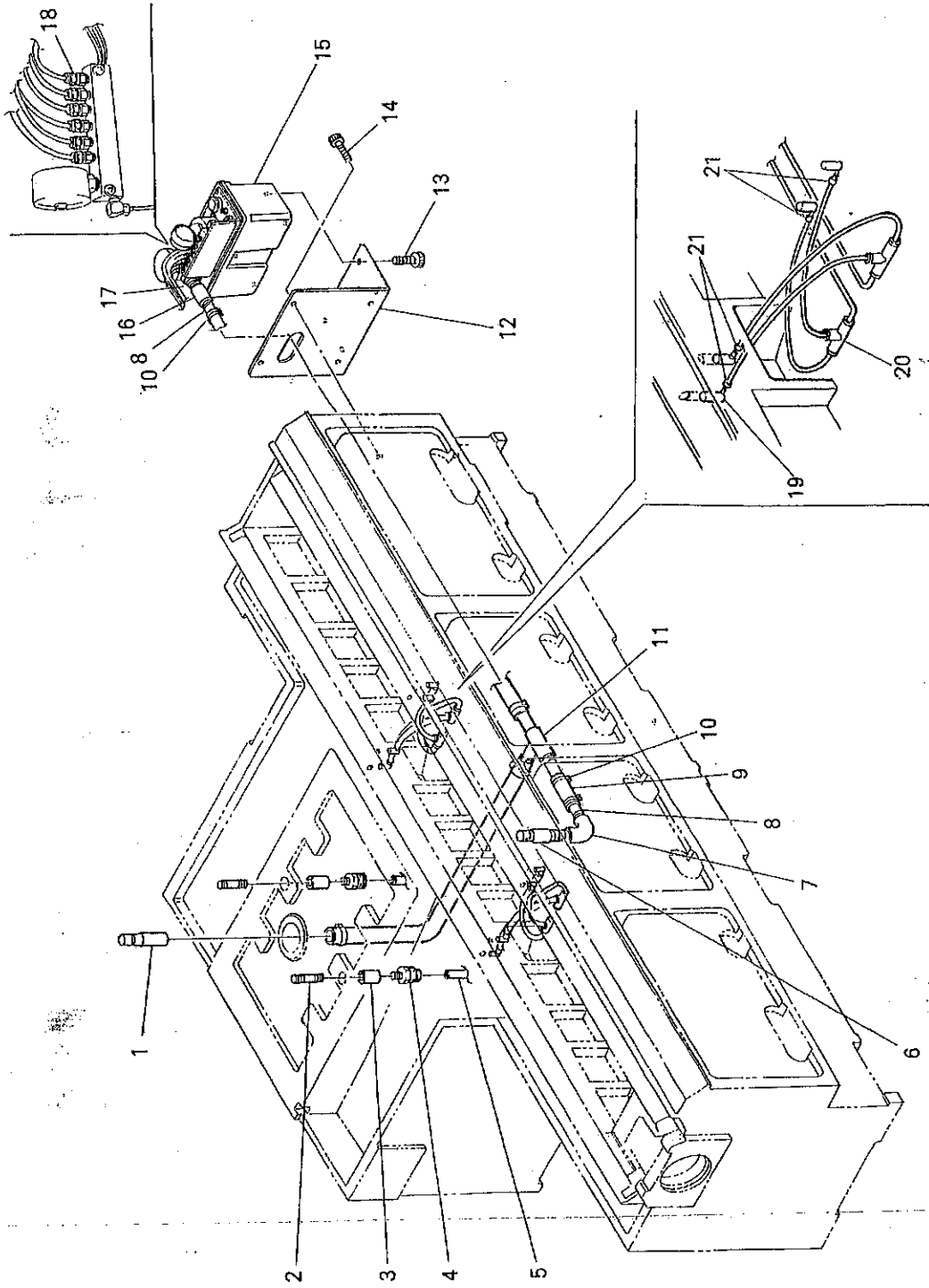

TABLE ASSEMBLY 2/2

NO.	PART CODE	PART NAME	Q'TY															
			340P		360P		3100P		3160P		340U		360U		3100U		3160U	
			12-16P	12-24P	12-24P	3	3	12-40P	12-40P	12-60P	12-60P	12-16U	12-16U	12-24U	12-24U	12-40U	12-40U	12-60U
49	5050172-01	HS 10 x 20	3	3		3	3		3	3		3	3		3	3		3
50	5051366A2	TFカバーミギダイ	1	-		-	-		-	1		-	-		-	-		-
	5050123C2	TFカバーミギダイ	-	1		-	-		-	-		1	-		-	-		-
	5050166B2	TFカバーミギダイ	-	-		1	-		-	-		-	-		1	-		-
51	5051365-02	HS 4 x 10	2	-		-	-		-	2		-	-		-	-		-
	5050122-02	HS 4 x 10	-	2		-	-		-	-		2	-		-	-		-
	5050167-02	HS 4 x 10	-	-		2	-		-	-		-	-		2	-		-
52	5051365-01	ザガネツキゴムアシ P-21#5	2	-		-	-		-	2		-	-		-	-		-
	5050122-01	ザガネツキゴムアシ P-21#5	-	2		-	-		-	-		2	-		-	-		-
	5050167-01	ザガネツキゴムアシ P-21#5	-	-		2	-		-	-		-	-		2	-		-
53	5051365A2	TFカバーミギシヨウ	1	-		-	-		-	1		-	-		-	-		-
	5050122D2	TFカバーミギシヨウ	-	1		-	-		-	-		1	-		-	-		-
	5050167B2	TFカバーミギシヨウ	-	-		1	-		-	-		-	-		1	-		-
54	J-942-365-3	TFカバーヒダリ	-	-		-	-		-	-		1	-		-	-		1
55	J-942-364-1	TFカバーミギ	-	-		-	-		-	-		1	-		-	-		1

PIPE ARRANGEMENT ASSEMBLY



PIPE ARRANGEMENT ASSMBLY

NO.	PART CODE	PART NAME	Q'TY											
			340P 12-16P	360P 12-24P	3100P 12-40P	3160P 12-60P	340U 12-16U	360U 12-24U	3100U 12-40U	3160U 12-60U				
1	5050176-06	ロックニッブル 1/2"	1	1	1	1	1	1	1	1	1	1	1	
2	5050176-15	ニッブル 1/8"	2	2	2	2	2	2	2	2	2	2	2	
3	5050176-16	ソケット 1/8"	2	2	2	2	2	2	2	2	2	2	2	
4	5050176-08	ニッブル PD4	2	2	2	2	2	2	2	2	2	2	2	
5050176-09	5050176-09	継付プラグ PAA4	2	2	2	2	2	2	2	2	2	2	2	
5050176-10	5050176-10	スリーブ PB4	2	2	2	2	2	2	2	2	2	2	2	
5050176-11	5050176-11	チューブインサート AL4	2	2	2	2	2	2	2	2	2	2	2	
5	5150038-07	パイプ φ4 × φ2.5 × 10m	1	1	1	1	1	1	1	1	1	1	1	
6	5050047-12	長ニッブル 1/2" × 110	1	1	1	1	1	1	1	1	1	1	1	
5050000-12	5050000-12	長ニッブル 1/2" × 110	-	1	-	-	-	-	-	1	-	-	-	
5050036-12	5050036-12	長ニッブル 1/2" × 110	-	-	1	-	-	-	-	1	-	-	-	
5050037-12	5050037-12	長ニッブル 1/2" × 110	-	-	-	1	-	-	-	-	-	-	1	
7	5050047-13	エルボ 1/2"	1	-	-	-	-	1	-	-	-	-	-	
5050000-13	5050000-13	エルボ 1/2"	-	1	-	-	-	-	-	-	1	-	-	
5050036-13	5050036-13	エルボ 1/2"	-	-	1	-	-	-	-	-	1	-	-	
5050037-13	5050037-13	エルボ 1/2"	-	-	-	1	-	-	-	-	-	-	1	
8	5050047-08	ロックニッブル 1/2"	5	-	-	-	-	5	-	-	-	-	-	
5050000-08	5050000-08	ロックニッブル 1/2"	-	5	-	-	-	-	5	-	-	-	-	
5050036-08	5050036-08	ロックニッブル 1/2"	-	-	5	-	-	-	-	5	-	-	-	
5050037-08	5050037-08	ロックニッブル 1/2"	-	-	-	5	-	-	-	-	-	-	5	
9	5050047-10	ビニールホース φ19 × φ26	1	-	-	-	-	1	-	-	-	-	-	
5050000-10	5050000-10	ビニールホース φ19 × φ26	-	1	-	-	-	-	-	-	1	-	-	
5050036-10	5050036-10	ビニールホース φ19 × φ26	-	-	1	-	-	-	-	-	-	1	-	
5050037-10	5050037-10	ビニールホース φ19 × φ26	-	-	-	1	-	-	-	-	-	-	1	
10	5050047-11	ホースバンド φ28	6	-	-	-	-	6	-	-	-	-	-	
5050000-11	5050000-11	ホースバンド φ28	-	6	-	-	-	-	6	-	-	-	-	
5050036-11	5050036-11	ホースバンド φ28	-	-	6	-	-	-	-	6	-	-	-	
5050037-11	5050037-11	ホースバンド φ28	-	-	-	6	-	-	-	-	-	-	6	
11	5050047-09	チー 1/2"	1	-	-	-	-	1	-	-	-	-	-	
5050000-09	5050000-09	チー 1/2"	-	1	-	-	-	-	-	-	1	-	-	

PIPE ARRANGEMENT ASSEMBLY

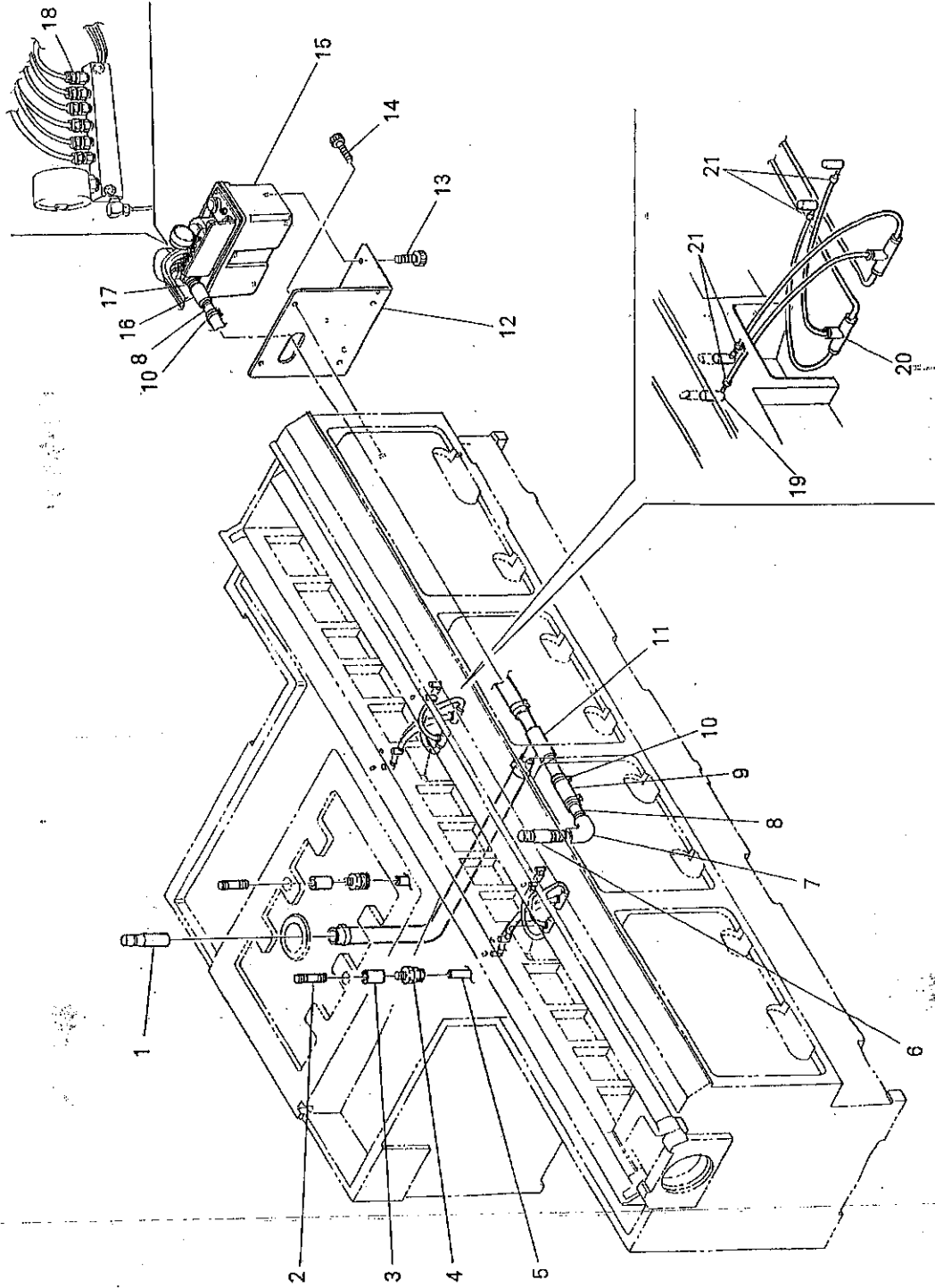

PIPE ARRANGEMENT ASSMBLY

NO.	PART CODE	PART NAME	Q'TY															
			340P		360P		3100P		3160P		340U		360U		3100U		3160U	
			12-16P	12-24P	12-24P	12-40P	12-60P	12-16U	12-24U	12-40U	12-40U	12-16U	12-24U	12-40U	12-40U	12-60U	12-60U	
11	5050036-09	チー 1/2"	-	-	-	1	-	-	-	-	-	-	-	-	-	-	-	
	5050037-09	チー 1/2"	-	-	-	-	1	-	-	-	-	-	-	-	-	-	1	
12	5150038C2	潤滑ポンプ台	1	1	1	1	1	1	1	1	1	1	1	1	1	1	1	
13	5150038-06	HS 8 × 10	4	4	4	4	4	4	4	4	4	4	4	4	4	4	4	
14	5150038-05	HS 6 × 10	4	4	4	4	4	4	4	4	4	4	4	4	4	4	4	
15	5150038-01	潤滑タンク	1	1	1	1	1	1	1	1	1	1	1	1	1	1	1	
16	5150038-07	ソケット 1/2"	1	1	1	1	1	1	1	1	1	1	1	1	1	1	1	
17	5150038-08	ニップル 1/2"	1	1	1	1	1	1	1	1	1	1	1	1	1	1	1	
18	5050038-02	プロパーナット PAN4	6	6	6	6	6	6	6	6	6	6	6	6	6	6	6	
	5050038-03	スリーブ PB4	6	6	6	6	6	6	6	6	6	6	6	6	6	6	6	
	5050038-04	チューブインサート AL4	6	6	6	6	6	6	6	6	6	6	6	6	6	6	6	
19	5050047-05	チューブエンド No.106927	8	-	-	-	-	-	-	-	8	-	-	-	-	-	-	
	5050000-05	チューブエンド No.106927	-	8	-	-	-	-	-	-	-	8	-	-	-	-	-	
	5050036-05	チューブエンド No.106927	-	-	-	8	-	-	-	-	-	-	8	-	-	-	-	
	5050037-05	チューブエンド No.106927	-	-	-	-	-	-	-	-	-	-	-	8	-	-	8	
20	5050047-06	ユニオンティー MAQ64-P-4	4	-	-	-	-	-	-	-	4	-	-	-	-	-	-	
	5050000-06	ユニオンティー MAQ64-P-4	-	4	-	-	-	-	-	-	-	4	-	-	-	-	-	
	5050036-06	ユニオンティー MAQ64-P-4	-	-	-	4	-	-	-	-	-	-	4	-	-	-	-	
	5050037-06	ユニオンティー MAQ64-P-4	-	-	-	-	-	-	-	-	-	-	-	4	-	-	4	
21	5050047-08	チューブバンド PZ4	8	-	-	-	-	-	-	-	8	-	-	-	-	-	-	
	5050000-08	チューブバンド PZ4	-	8	-	-	-	-	-	-	-	8	-	-	-	-	-	
	5050036-08	チューブバンド PZ4	-	-	-	8	-	-	-	-	-	-	8	-	-	-	-	
	5050037-08	チューブバンド PZ4	-	-	-	-	-	-	-	-	-	-	-	8	-	-	8	

CONTROL BOX ASSEMBLY

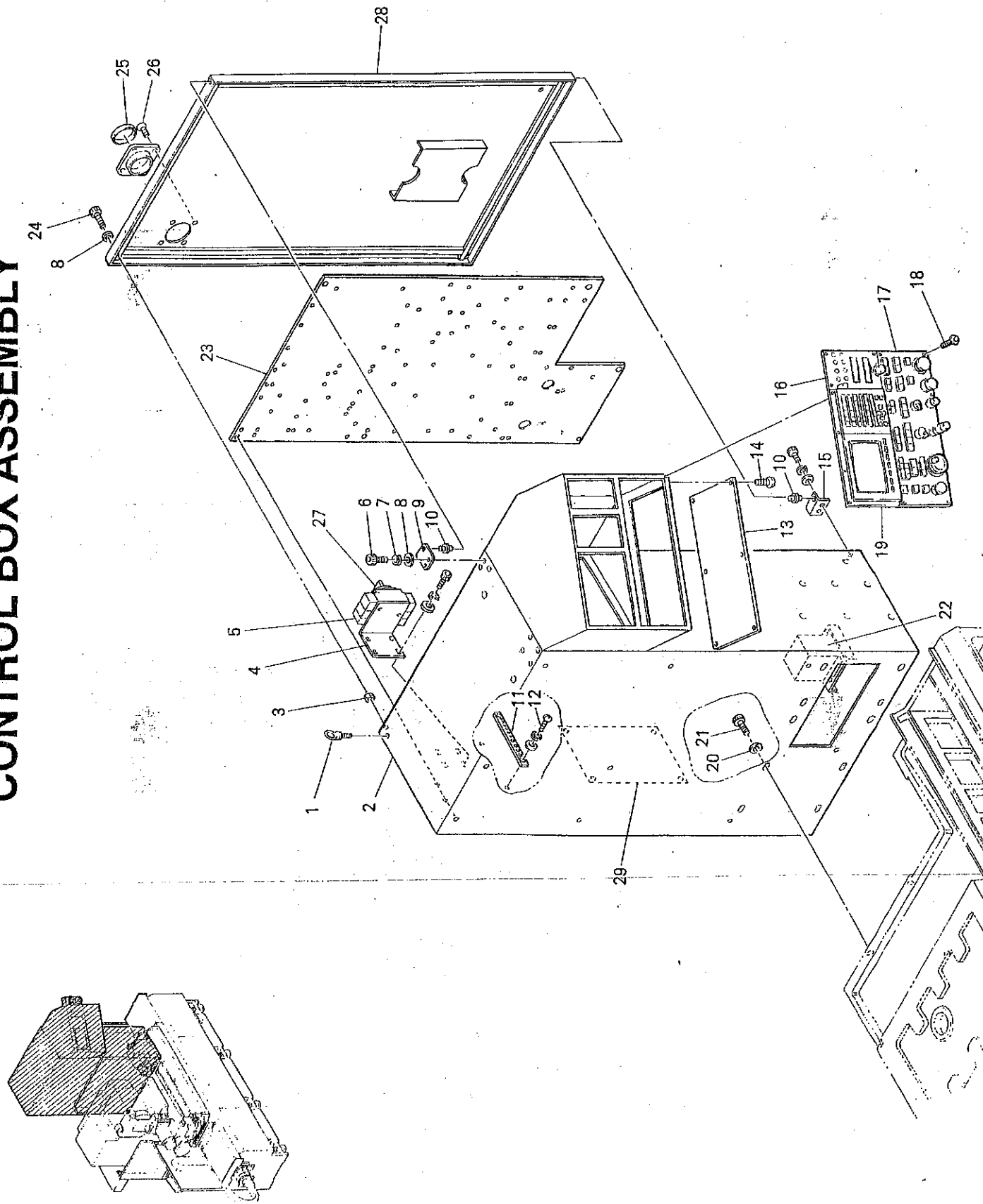

CONTROL BOX ASSEMBLY

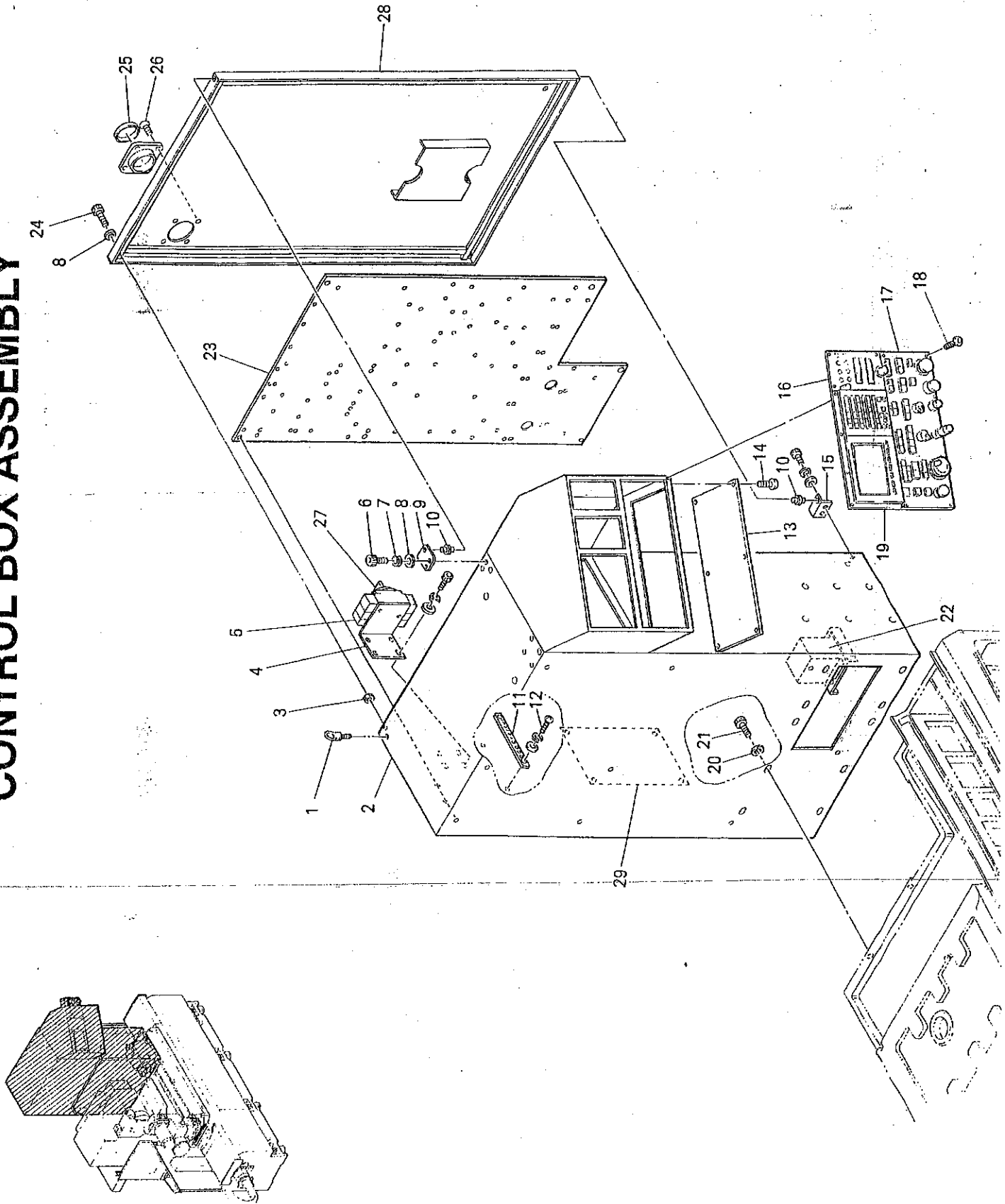

ELECTRICAL ASSEMBLY

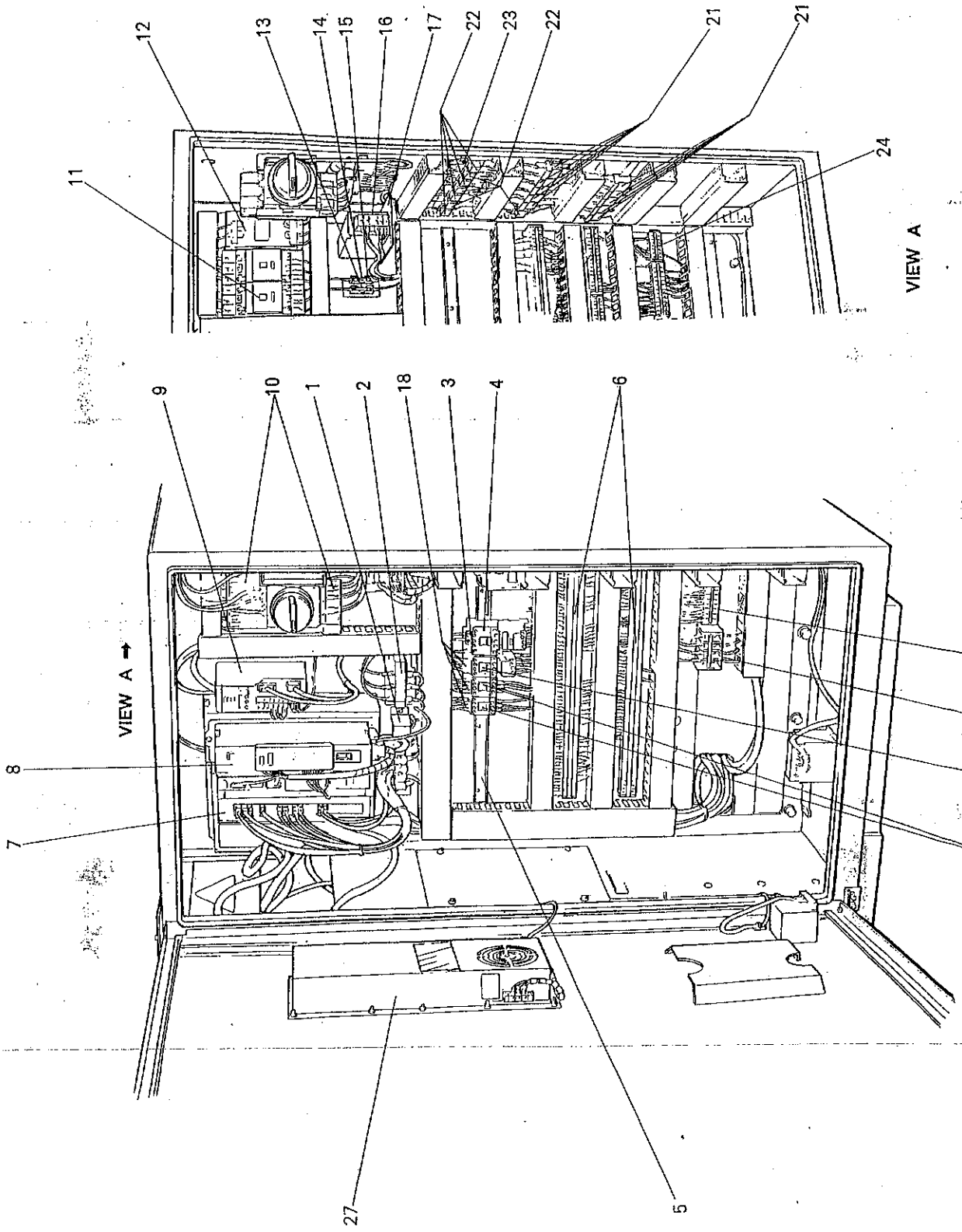

NAME PLATE 1/2

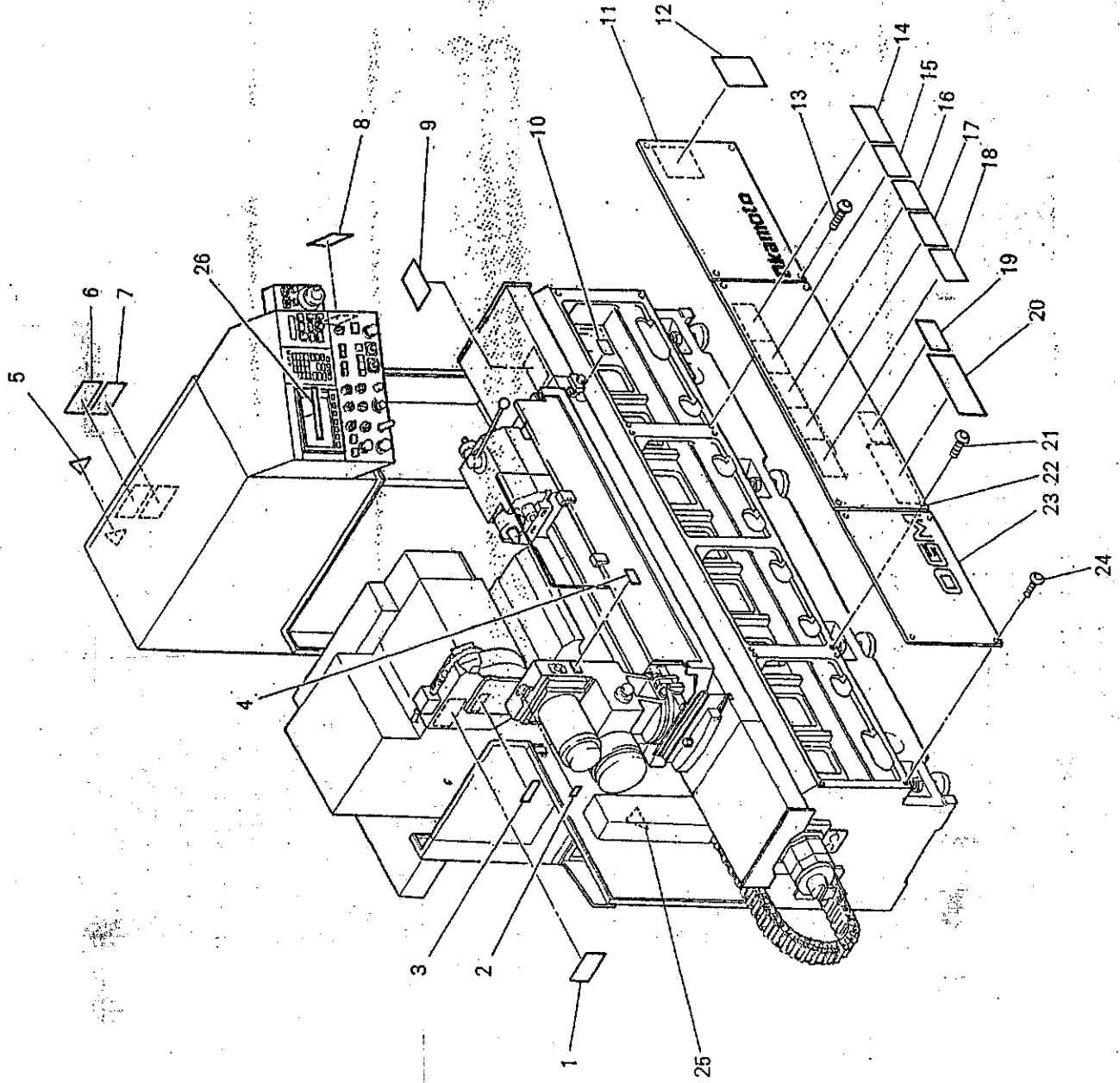

NAME PLATE 1/2

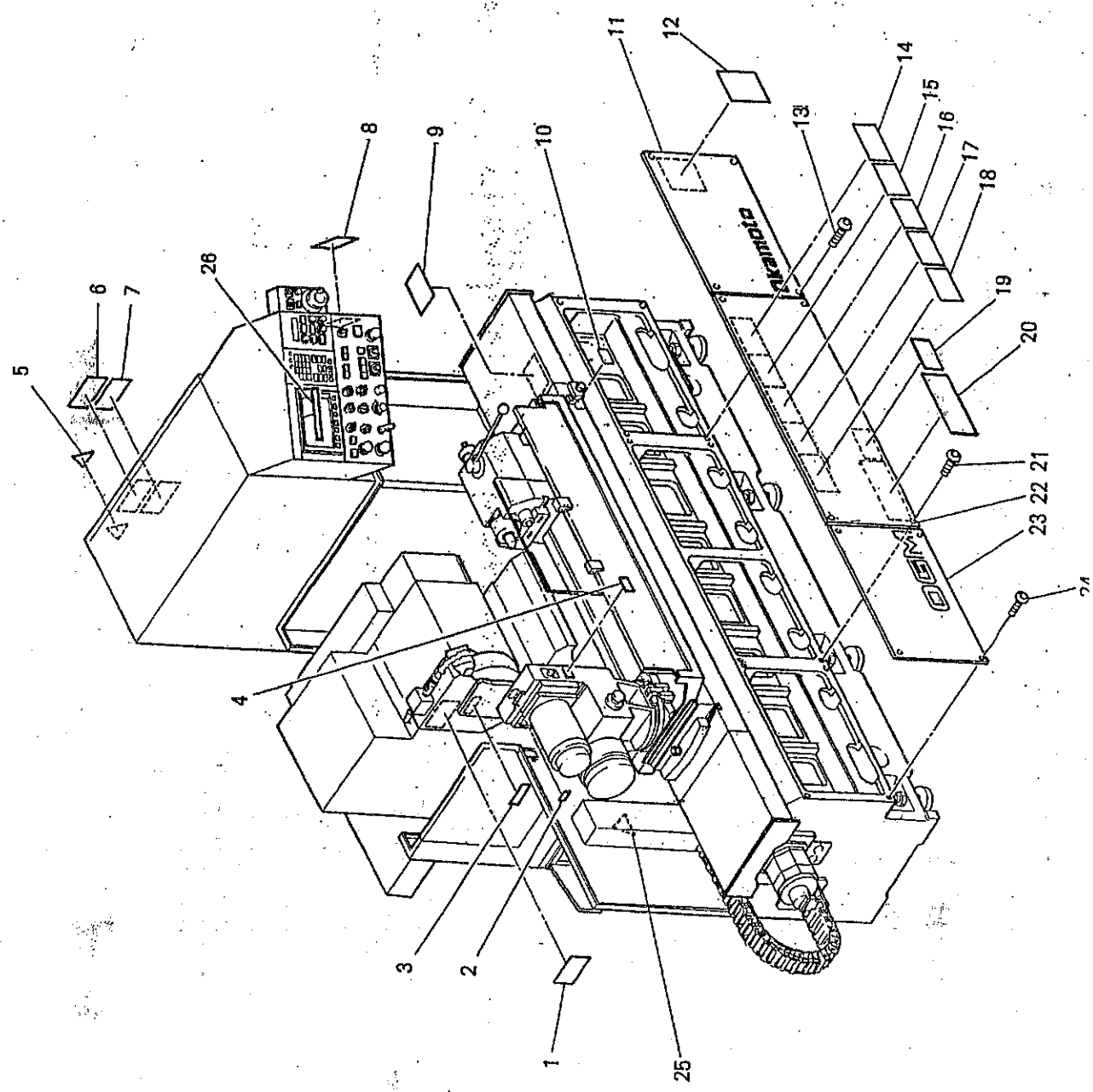

NAME PLATE 2/2

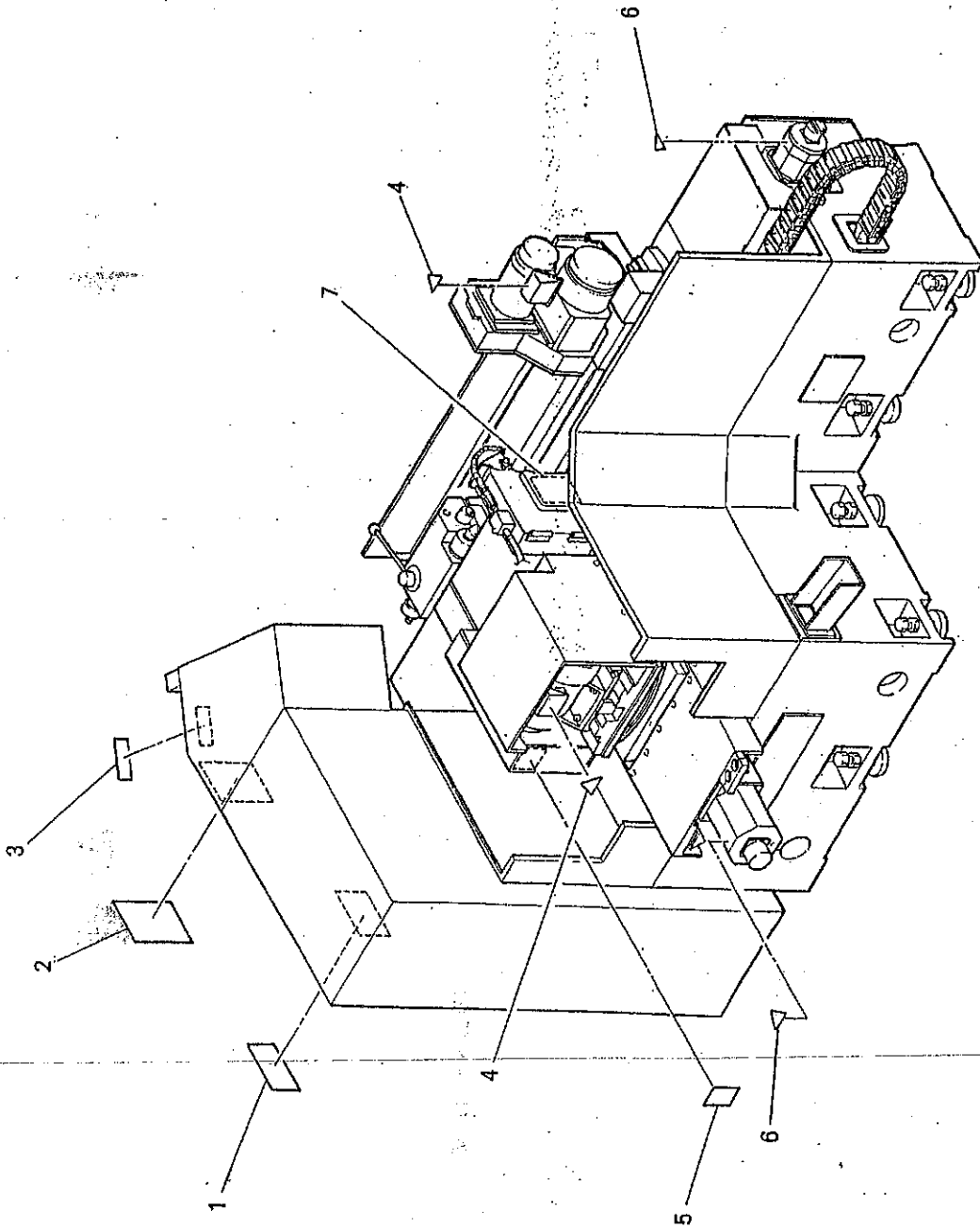

COOLANT SYSTEM ASSEMBLY

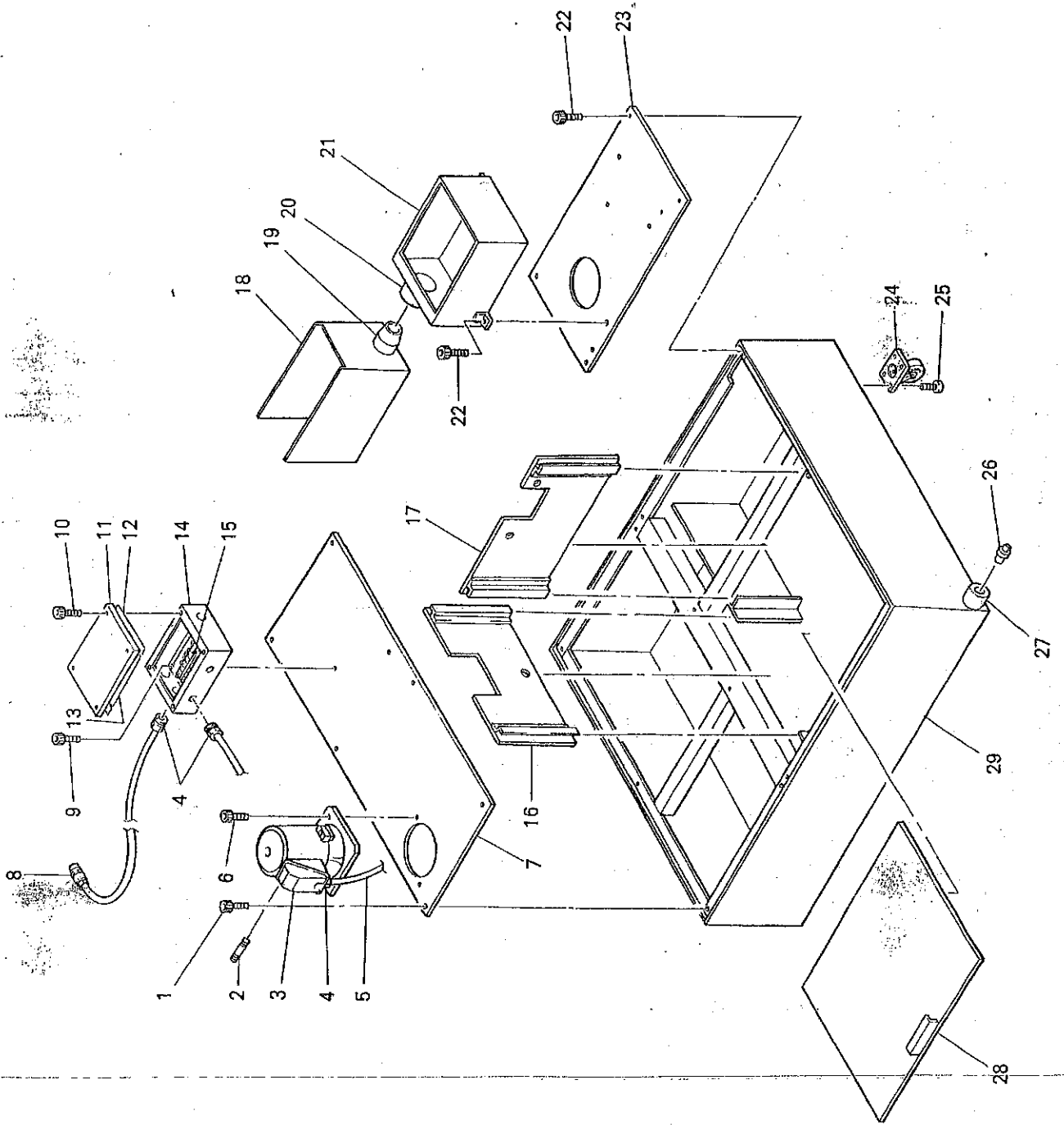
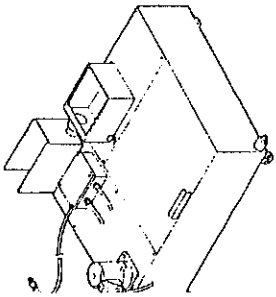

Okamoto Machine Tool Works, Ltd

Head Office

3009 Kamiechi, Atsugi, Kanagawa, Japan. 243-0801 Tel: (046) 286-9212 Fax: (046) 286-9114

Annaka Plant

2993 Osato Gobara Annaka T379-01, Japan. Tel: 0273 (85) 5111 Fax: 0273 (85) 5122

Atsugi Plant

3009 Uenohara, Kamiyechi Atsugi T243, Japan. Tel: 046 (86) 3561 Fax: 046 (86) 2243

Singapore Branch

10 Riverside Road, Singapore 739082, Republic of Singapore. Tel: (65) 3623818 Fax: (65) 3623368

Okamoto Machinery Co., Ltd.

2050 Kanami Kanae-cho Fukuyama T720-05, Japan. Tel: 0849 (35) 9191 Fax: 0849 (35) 9132

Okamoto Corporation *370 Corporate Woods Pkwy; Vernon Hills IL 60061 USA*
~~1500 Busch Parkway Buffalo Grove, Illinois 60089 U.S.A. Tel: (708) 520-7700 Fax: (708) 520-7980~~
Ph. *847-235-3500* Service Fax: *847-235-3272*
Parts " " " - *3270*

Okamoto Machine Tool Europe GmbH

Rudolf-Diesel-StraBe 20, 65760 Eschborn-Niederhochstadt, Germany. Tel: (06173) 640841
Fax: (06173) 640442

Okamoto Singapore Pte. Ltd.

10 Riverside Road, Singapore 739082, Republic of Singapore. Tel: (65) 2696426 (6 lines) Fax: (65) 2690832

Okamoto (Thai) Co., Ltd.

174, MU2, Tambol Chamaeb Amphur Wangnoi Changwat, Ayudhaya 13170, Thailand. Tel: (035) 271187-90
Fax: (035) 271191